

ADULT LITERACY FUNDAMENTAL MATHEMATICS

Book Five

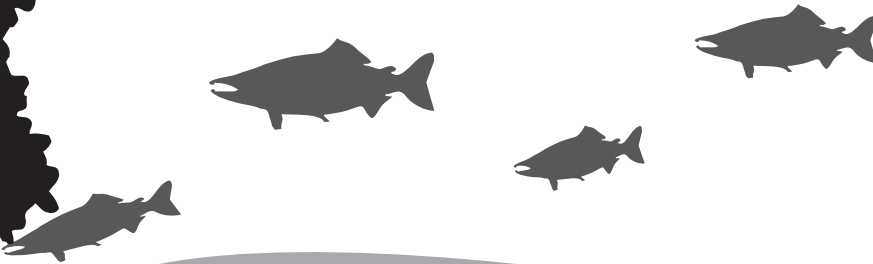
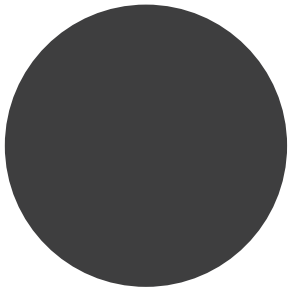

ABE
ADULT BASIC
EDUCATION

Adult Literacy Fundamental Mathematics

Book 5

Prepared by Liz Girard

Based on the work of Leslie Tenta (1993) and Marjorie E. Enns (1983)
Steve Ballantyne, Lynne Cannon, James Hooten, Kate Nonesuch (1994)

Canadian Cataloguing in Publication Data

Downloading Information

<http://urls.bccampus.ca/abefundmath5>

ISBN 978-0-7726-6302-3

Adult Literacy Fundamental Mathematics Book 1

ISBN 978-0-7726-6303-0

Adult Literacy Fundamental Mathematics Book 2

ISBN 978-0-7726-6304-7

Adult Literacy Fundamental Mathematics Book 3

ISBN 978-0-7726-6305-4

Adult Literacy Fundamental Mathematics Book 4

ISBN 978-0-7726-6306-1

Adult Literacy Fundamental Mathematics Book 5

ISBN 978-0-7726-6307-8

Adult Literacy Fundamental Mathematics Book 6

ISBN 978-0-7726-6347-4

Adult Literacy Fundamental Mathematics, Instructor's Manual and Test Bank

Copyright © 2010 Province of British Columbia
Ministry of Advanced Education and Labour Market Development
Permission Granted to make copies for educational purposes.

Acknowledgments

Curriculum Writers:

Liz Girard, North Island College

Wendy Tagami, Selkirk College

Advisory Committee members:

Jill Auchinachie, Camosun College

Leanne Caillier-Smith, College of the Rockies

Mercedes de la Nuez, Northwest Community College

Barbara Stirsky, University of the Fraser Valley

Jan Weiten, Vancouver Community College

The Deans and Directors of Developmental Education

North Island College

Selkirk College

Stephanie Jewell, Vancouver Community College

Vivian Hermansen, North Island College

Lyle Olsen, Selkirk College

Allison Alder, Selkirk College

The Adult Literacy Fundamental Working Group

Cheryl Porter, North Island College

Stephen & Jennifer Marks, Layout editors

Table of Contents

Unit One: Common Fractions

| | |
|---|-----------|
| Topic A: Introducing Common Fractions | 2 |
| Writing Common Fractions..... | 5 |
| How do we read common fractions? | 11 |
| How do we compare common fractions?..... | 15 |
| Comparing Fractions with Different Denominators | 22 |
| | |
| Topic B: Common Fractions | 26 |
| Writing Improper Fractions as Mixed Numbers..... | 35 |
| Renaming Mixed Numbers as Improper Fractions..... | 38 |
| To Say or Write a Mixed Number | 44 |
| | |
| Topic C: When to Use a Fraction or a Decimal | 48 |
| | |
| Unit One Review | 50 |

Unit Two: Equivalent Fractions

| | |
|--|-----------|
| Topic A: Equivalent Fractions | 62 |
| Finding Common Factors..... | 68 |
| Expressing Fractions in Lower Terms | 72 |
| Expressing Fractions in Higher Terms | 77 |
| Are the Fractions Equivalent? | 78 |
| Rounding Common Fractions to Whole Numbers | 81 |
| | |
| Unit 2 Review | 86 |

Unit Three: Multiplying & Dividing Fractions

| | |
|--|-----------|
| Topic A: Multiplying Fractions | 96 |
| Multiplying a Whole Number and a Proper Fraction | 103 |
| Multiplying Common Fractions Together | 108 |
| Simplify Before Multiplying | 111 |

| | |
|---|---------|
| Multiplying Mixed Numbers | 116 |
| Problems using Multiplication of Common Fractions | 124 |
| Reciprocals | 137 |
| Multiplying by the Reciprocal | 140 |
| Problems Which Use Division of Common Fractions | 150 |
| Unit 3 Review | 155 |

Unit Four: Adding & Subtracting Common Fractions

| | |
|---|----------------|
| Topic A: Adding Common Fractions | 168 |
| Adding Mixed Numbers | 179 |
| Problems Using Addition of Common Fractions | 205 |
| Topic B: Subtracting Common Fractions | 212 |
| Subtracting Mixed Numbers from Whole Numbers..... | 221 |
| Renaming to Subtract Mixed Numbers | 226 |
| Problems Using Subtraction of Common Fractions | 235 |
| Topic C: Problems Using Common Fractions | 240 |
| Unit 4 Review..... | 247 |

Unit Five: Common Fractions & Decimals

| | |
|--|-----------------|
| Topic A: Common Fractions & Decimals | 258 |
| Writing Decimals as Common Fractions | 259 |
| Some Tricky Conversions | 261 |
| Writing Common Fractions as Decimals | 262 |
| Topic B: Comparing Fractions and Decimals | 272 |
| Comparing Fractions to Decimals and Decimals to Fractions..... | 274 |
| Unit 5 Review | 279 |
| Glossary | 2839 |

To the Learner:

Welcome to Fundamental Mathematics Book Five.

Adult Math Learners

You have the skills you need to be a strong student in this class. Your instructor knows this because you have passed the Fundamental Math Level Four class, or you have been assessed into this level.

Adult math learners have many skills. They have a lot of life experience, they also use math in their everyday lives. This means that adult math learners may already know some of what is being taught in this book. Use what you already know with confidence!

Grades Record

You have also been given a sheet to write down your grades. After each test, you can write in the mark. This way you can keep track of your grades as you go through the course. This is a good idea to use in all your courses. You can find this grade sheet at the end of the book.

How to Use this Book

This textbook has:

- ✓ A **Table of Contents** listing the units, the major topics and subtopics.
- ✓ A **Glossary** giving definitions for mathematical vocabulary used in the course.
- ✓ A **grades record** to keep track of your marks.

The textbook has many exercises; some are quite short, but others have a great number of questions. **You do not have to do every single question!**

- Do as many questions as **you** feel are necessary for you to be confident in your skill.
- It is best to do **all** the word problems.
- If you leave out some questions, try doing every second or every third question. Always do some questions from the end of each exercise because the questions usually get harder at the end. You might use the skipped questions for review before a test.
- If you are working on a difficult skill or concept, do half the exercise one day and finish the exercise the next day. That is a much better way to learn.

Self-tests at the end of most topics have an **Aim** at the top. If you do not meet the aim, talk to your instructor, find what is causing the trouble, and do some more review before you go on.

A **Review and Extra Practice** section is at the end of each unit. If there is an area of the unit that you need extra practice in, you can use this. Or, if you want, you can use the section for more review.

A **Practice Test** is available for each unit. You may:

- Write the practice test after you have studied the unit as a practice for the end-of-chapter test, OR
- You might want to write it before you start the unit to find what you already know and which areas you need to work on.

Unit tests are written after each unit. Again, you must reach the **Aim** before you begin the next unit. If you do not reach the aim, the instructor will assist you in finding and practising the difficult areas. When you are ready, you can write a B test to show that you have mastered the skills.

A **Final Test** is to be written when you have finished the book. This final test will assess your skills from the whole book. You have mastered the skills in each unit and then kept using many of them throughout the course. The test reviews all those skills.

Math Anxiety

Math anxiety, or the fear of math, is something many people experience. It is a learned habit and can be unlearned. Math anxiety can happen for a few different reasons:

- Feeling anxious when writing tests
- Negative experiences in a past math class
- Embarrassment in a past math class
- Social pressures and expectations to not like math or not do well in math
- The want to get everything right
- Negative self-message (“I don’t know how to do it”, or “I hate math”)

Everyone can learn math. There is no special talent people are born with that make them better at math. There are some people who are better at math than others, but even those people had to learn math to be good at it.

Do you suffer from math anxiety?

Read the list below and put a check mark beside the ones you feel when thinking about or doing math.

| | |
|--|---|
| | Are your palms moist? |
| | Is your stomach fluttering? |
| | Do you feel like you can’t think clearly? |
| | Do you feel like you would rather do anything else than learn math? |
| | Are you breathing faster than normal? |
| | Is your heart pounding? |
| | Do you feel cold? |
| | Do you feel sweaty? |

If you answered yes to two or more of these items, you may have math anxiety.

How to deal with Math Anxiety

Anyone can feel math anxiety. It will slow down your learning. The key to learning math is to be the “boss” of your anxiety.

One way to be the “boss” is to give yourself positive math messages.

Read and think about the positive math messages listed below. Do you say any of those things to yourself?

- If the answer is **yes**, then great, keep doing that.
- If your answer is **no**, try to add this little mental trick to your day. The result will probably be that you start to see math as something you can do and that you may even like!

I like math.

I am good at math.

I understand math.

I can relax when I am studying math.

I am capable of learning math.

Math is my friend.

My math improves every day.

I am relaxed, calm and confident when I study math.

I understand math when I give myself a chance.

Math is creative.

Pick three statements that you like and say them to yourself as much as you can in each day. You can also write the statements out on paper and post them around your house so that you read them throughout the day.

Grades Record

Book 5

| Unit | Practice Test | Date of Test A | Test A | Date of Test B | Test B |
|-------------------|---------------|----------------------|-----------------|----------------------|-----------------|
| <i>Example</i> | √ | <i>Sept. 4, 2011</i> | $\frac{25}{33}$ | <i>Sept. 7, 2011</i> | $\frac{28}{33}$ |
| 1 | | | | | |
| 2 | | | | | |
| 3 | | | | | |
| 4 | | | | | |
| 5 | | | | | |
| Final Test | | | | | |

Unit 1

Common Fractions

Topic A: Introducing Common Fractions

This unit gives you the background details that you need for working with **common** fractions.

Common fractions are written with two numbers, one above the other, with either a straight or slanted line in between. The straight line style is the one used most.

$$\begin{array}{c} \boxed{\text{numerator}} \longrightarrow 4 \\ \hline 5 \longleftarrow \boxed{\text{denominator}} \end{array}$$

The **denominator** is the bottom number. It tells how many equal parts are in the whole thing. The **numerator** is the top number. It tells how many of the **equal** parts we are dealing with.

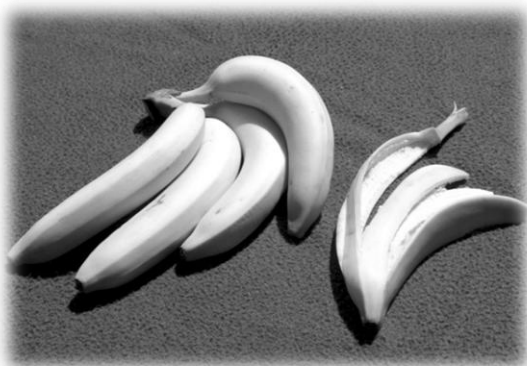

The whole thing is the bunch of bananas.
The whole thing has 5 equal parts (the bananas). The denominator is **5**.

How many bananas have been eaten? **1**
What fraction of the bananas have been eaten?
— of the bananas



The whole thing is a carton of one dozen eggs.
One dozen has 12 equal parts, so if we are talking about the carton, the denominator is **12**.

How many eggs are still in the carton? **7**
What fraction of the eggs are left?
— of the eggs

A fraction is always looking at things as **parts of a whole**. In the example of the eggs above, the **whole** is 12 eggs. The **part** is the 7 eggs that are left. 7 is part of the whole of 12.

Example A:

This pizza is **one whole** pizza. The pizza is cut into 8 pieces. This means the whole is 8. How many parts are left? (the pieces that are shaded are the ones left) Write a fraction of how many pieces of pizza are left:

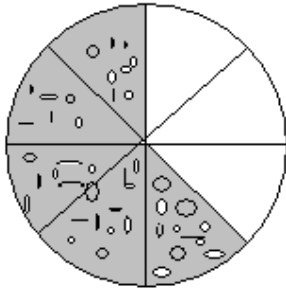

The amount left over can be shown as a fraction: $\frac{5}{8}$

Example B:

It is Peter's 82nd birthday. There were 8 people, including Peter, at the party. Everyone wants a small piece of cake, so Kathleen cut the cake into 12 equal parts. This means the **whole** is 12. There will be some left over.

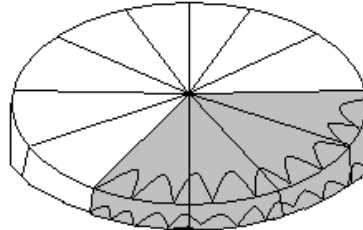

The amount left over can be shown as a fraction: $\frac{4}{12}$

Example C:

Sue made a strawberry pie to share with her family of 4. The pie was cut into 8 equal parts. This means the **whole** is 8. The kids are excited because there will be parts left over.

The fraction showing what amount of pie is left is: $\frac{4}{8}$

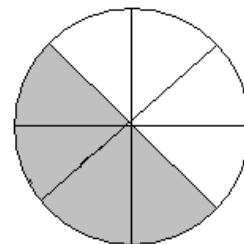

Exercise One

Look at the fraction below. Fill in the blank labels with the four terms you are given:

Numerator
Denominator
Whole
Fraction

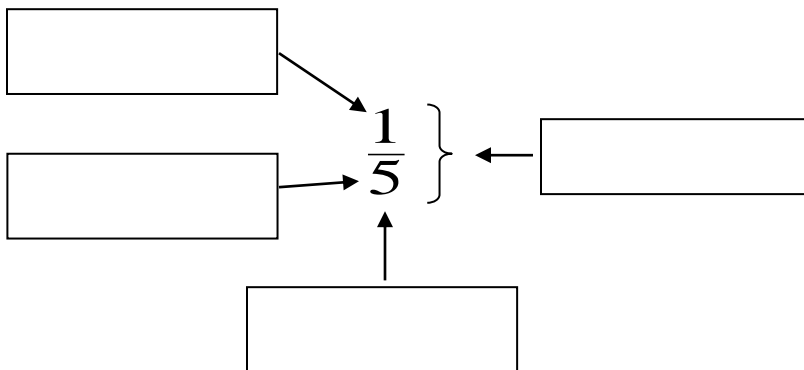

Answers to Exercise One

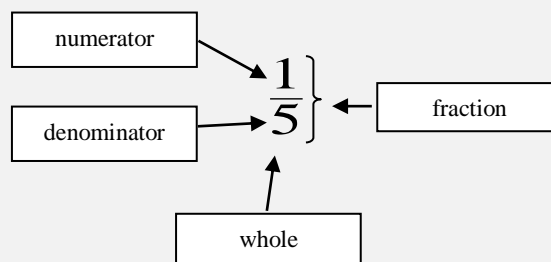

Writing Common Fractions

Exercise Two

Each shape drawn here is a whole. The shapes have been divided into parts.

1. Ask yourself "How many equal parts in the whole?" That number is the denominator.
2. Count the number of parts that are shaded ; that is the numerator.
3. Write the common fraction to describe the shaded portion of each shape.

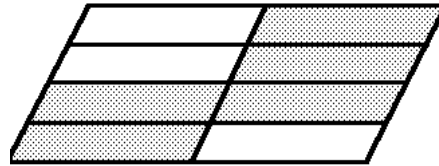
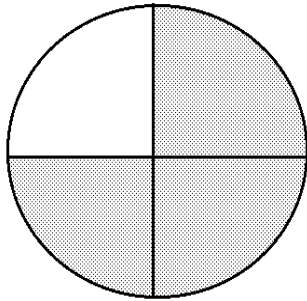

a) i) How many parts
make the whole? 4

ii) How many parts
are shaded? 3

iii) Fraction: $\frac{3}{4}$

b) i) How many parts
make the whole? _____

ii) How many parts
are shaded? _____

iii) Fraction: _____

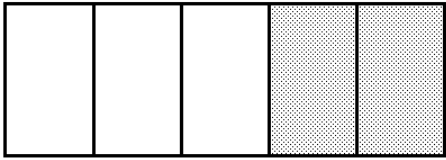

c) i) How many parts make the whole? _____

ii) How many parts are shaded? _____

iii) Fraction: _____

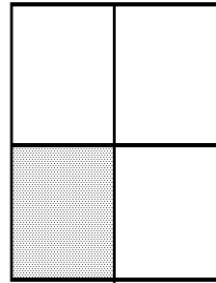

d) i) How many parts make the whole? _____

ii) How many parts are shaded? _____

iii) Fraction: _____

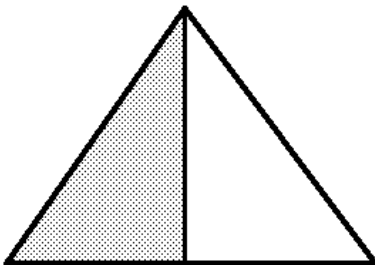

e) i) How many parts make the whole? _____

ii) How many parts are shaded? _____

iii) Fraction: _____



f) i) How many parts make the whole? _____

ii) How many parts are shaded? _____

iii) Fraction: _____

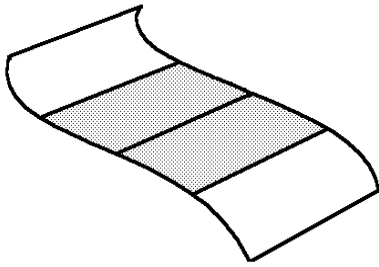

g) i) How many parts make the whole? _____

ii) How many parts are shaded? _____

iii) Fraction: _____

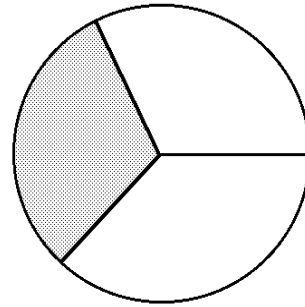

h) i) How many parts make the whole? _____

ii) How many parts are shaded? _____

iii) Fraction: _____

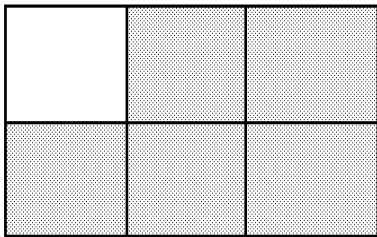

i) i) How many parts make the whole? _____

ii) How many parts are shaded? _____

iii) Fraction: _____

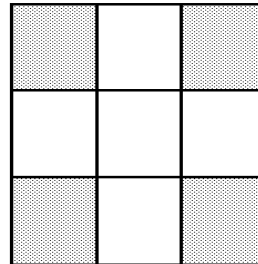

j) i) How many parts make the whole? _____

ii) How many parts are shaded? _____

iii) Fraction: _____

Answers to Exercise Two

a) i) 4 ii) 3 iii) $\frac{3}{4}$

b) i) 8 ii) 5 iii) $\frac{5}{8}$

c) i) 5 ii) 2 iii) $\frac{2}{5}$

d) i) 4 ii) 1 iii) $\frac{1}{4}$

f) i) 13 ii) 5 iii) $\frac{5}{13}$

g) i) 4 ii) 2 iii) $\frac{2}{4}$

h) i) 3 ii) 1 iii) $\frac{1}{3}$

i) i) 6 ii) 5 iii) $\frac{5}{6}$

j) i) 9 ii) 4 iii) $\frac{4}{9}$

Exercise Three

Now draw some fractions.

Example:

Draw the fraction $\frac{1}{2}$ in a circle:

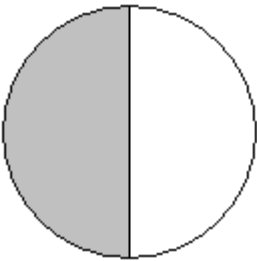

a) draw $\frac{1}{4}$ in a circle:

b) draw $\frac{1}{3}$ in a circle (here is a hint how):



c) draw $\frac{1}{2}$ in the rectangle:



d) draw $\frac{2}{4}$ in the rectangle:



e) draw $\frac{4}{8}$ in the rectangle:



f) What do you see in common with the three last boxes you just drew?

Answers to Exercise Three

a)

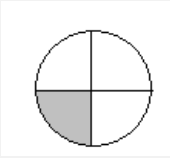

b)

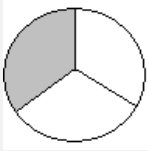

c)



d)



e)

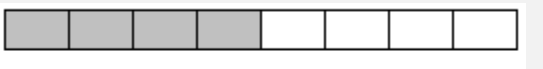

f) all the shaded spaces are the same.

How do we read common fractions?

You can read fractions in a few different ways:

$\frac{1}{2}$ can be called:

- One over two
- One half

$\frac{1}{4}$ can be called:

- One over four
- One fourth
- One quarter

$\frac{3}{4}$ can be called:

- Three over four
- Three fourths
- Three quarters

$\frac{1}{3}$ can be called

- One over three
- One third



Did you notice that the fractions with a denominator of four have an extra name? Do they seem familiar? No other fractions have a third name.

Here is how to read fractions:

Remember:

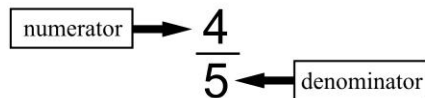

The numerator is read as a number.

The denominator is read with a special ending on the end of the numeral (called ordinal).

The ending is usually **th** or **ths** as it was in decimals, but sometimes we use a different word.

| If the denominator is... | Read... |
|---------------------------------|-------------------|
| 2 | half |
| 3 | third |
| 4 | fourth or quarter |
| 5 | fifth |
| 6 | sixth |
| 7 | seventh |
| 8 | eighth |
| 9 | ninth |
| 10 | tenth |
| 22 | twenty-second |

(these are called ordinal numbers)

Add the "s" if the numerator is 2 or more.

So $\frac{2}{3}$ is read "two-thirds".

Note that the usual practice is to put a hyphen (-) between the words when you write them out.

$\frac{1}{2}$ is usually read "one-half". $\frac{2}{2}$ is read "two-halves"

$\frac{3}{4}$ is read as "three-quarters" or "three-fourths".

Exercise Four

Look back again at Exercise Two and write down the word names for your answers.

a) three-quarters or three-fourths

b) _____

c) _____

d) _____

- e) _____
- f) _____
- g) _____
- h) _____
- i) _____
- j) _____

We make common fractions out of many things in our lives. For example,

- I got 13 out of 15 on my English test. The score is $\frac{13}{15}$.
- The baseball pitcher struck out 2 of the 6 batters in the inning.
 $\frac{2}{6}$ of the batters were struck out.
- Three of the eggs in that dozen are cracked. $\frac{3}{12}$ of the eggs are cracked.
- Finish your vegetables. I gave you just 8 pieces of carrot, and you have only eaten 4 of them! $\frac{4}{8}$ of the carrots are eaten.

Answers to Exercise Four

- | | | |
|------------------------------------|----------------|---------------------|
| a) three quarters or three fourths | b) five eights | c) two fifths |
| d) one quarter or one fourth | e) one half | f) five thirteenths |
| g) two quarters or two halves | h) one third | i) five sixths |
| j) four ninths | | |

Exercise Five

Answer the questions **using a common fraction**.

- a) $\frac{20}{30}$ Jill walks for 20 minutes of the 30 minute lunch break. What fraction of her lunch break does Jill walk?
- b) _____ The test was scored out of 25. Kim got 20 marks. Write his score.

- c) _____ The restaurant has 12 tables. Each waiter looks after 6 of them. What fraction of the tables does each waiter look after?
- d) _____ The new litter of puppies is a big one—10 pups. Three of the pups have floppy ears. What fraction of the puppies have floppy ears?
- e) _____ Beryl planted 3 dozen tulip bulbs last fall. A mole ate one dozen of them before they flowered. That mole is in trouble!! What fraction of the tulips did the mole eat?
- f) _____ Kay's raisin cookie recipe uses 5 cups of flour altogether. Kay always puts in 2 cups of whole wheat flour and 3 cups of white flour. What fraction of the flour that she uses is whole wheat?
- g) _____ Greg got 6 new golf balls for his birthday. On his first golf game, he lost two of them in the water trap. What fraction of the new balls has he lost?
- h) _____ The class has 18 students. 16 of the students are enrolled in the math course. What fraction of the class is taking math?
- i) _____ Kay made 72 delicious raisin cookies last night. Her teenage sons and their friends ate 36 of them. What fraction of the cookies did they eat?
- j) _____ Dave bought four litres of oil for his car. But when he changed the oil, he only needed to put in three litres. What fraction of the oil did he use?

Answers to Exercise Five

- a) $\frac{20}{30}$ b) $\frac{20}{25}$ c) $\frac{6}{12}$ d) $\frac{3}{10}$ e) $\frac{1}{3}$ f) $\frac{2}{5}$ g) $\frac{2}{6}$
- h) $\frac{16}{18}$ i) $\frac{36}{72}$ j) $\frac{3}{4}$



These common fractions that you have been writing are called **proper fractions**. **Proper fractions** are fractions where the numerator is smaller than the denominator.

How do we compare common fractions?

Example A:

a) Which circle has more shaded parts?

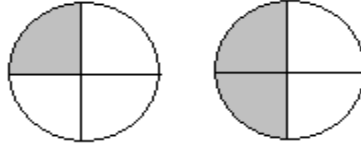

b) Yes, the one on the right has more shaded parts.

c) Which is larger: $\frac{1}{4}$ or $\frac{2}{4}$?

(Look back at the circles above to help answer this question).

Answer: $\frac{2}{4}$ is larger because it fills in more parts of the circle.

Example B:

Review: Greater than $>$ Less than $<$ Less than $<$ Greater than $>$



a) Which is shaded more?

_____ or _____

b) Write the fractions for both drawings:

_____ _____

c) Which fraction is larger? Place a symbol ($<$ or $>$) in the box above to show your answer.

Answer: $\frac{1}{4} < \frac{3}{4}$ is correct!

Exercise Six

1)



I. Shade $\frac{1}{6}$ and $\frac{5}{6}$

II. Circle the fraction that is larger.

III. Write a mathematical sentence stating which fraction is larger (use < or >)

_____ _____

2)

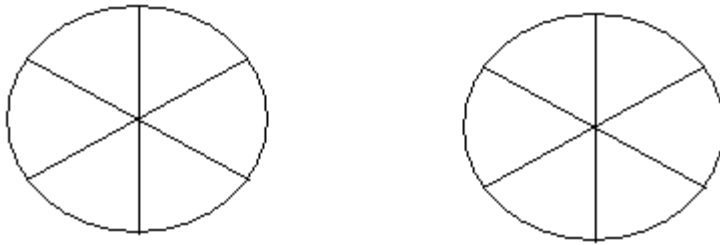

I. Shade: $\frac{4}{6}$ and $\frac{3}{6}$

II. Circle the fraction that is larger.

III. Write the mathematical sentence stating which fraction is larger (Use < or >).

_____ _____

3)

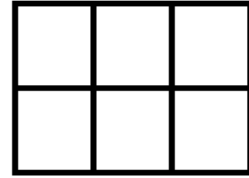
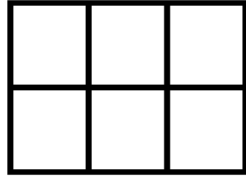

I. Shade: $\frac{2}{6}$ and $\frac{1}{6}$

II. Circle the fraction that is larger.

III. Write a mathematical sentence that shows which fraction is larger.

_____ _____

Answers to Exercise Six

1) $\frac{1}{6} < \frac{5}{6}$

2) $\frac{4}{6} > \frac{3}{6}$

3) $\frac{2}{6} > \frac{1}{6}$

There is a rule you can follow to compare fractions:

As the numerator gets larger and the denominator stays the same, the fraction gets larger.

Example: $\frac{3}{10} < \frac{7}{10}$

Exercise Seven

Use the < or > symbols to show which fraction is larger.

a) $\frac{3}{4}$ _____ $\frac{1}{4}$

d) $\frac{9}{10}$ _____ $\frac{1}{10}$

b) $\frac{5}{6}$ _____ $\frac{1}{6}$

e) $\frac{3}{8}$ _____ $\frac{5}{8}$

c) $\frac{3}{5}$ _____ $\frac{4}{5}$

f) $\frac{1}{5}$ _____ $\frac{4}{5}$

Answers to Exercise Seven

a) > b) > c) < d) > e) < f) <

Exercise Eight

Show which is larger by using < or >.

a) One fourth \leq Three fourths

d) Five ninths ____ two ninths

b) Five sixths ____ Four sixths

e) Seven sevenths ____ three sevenths

c) One eights ____ three eights

f) One third ____ two thirds

Answers to Exercise Eight

b) > c) < d) > e) > f) <

Exercise Nine

Compare many fractions with the same denominator by putting the fractions in order from smallest to largest.

a) $\frac{3}{4}, \frac{1}{4}, \frac{2}{4}$

b) $\frac{6}{7}, \frac{2}{7}, \frac{3}{7}, \frac{1}{7}, \frac{5}{7}, \frac{4}{7}$

c) $\frac{4}{10}, \frac{7}{10}, \frac{1}{10}, \frac{5}{10}, \frac{9}{10}$

d) $\frac{50}{361}, \frac{23}{361}, \frac{7}{361}, \frac{360}{361}, \frac{274}{361}, \frac{158}{361}$

Answers to Exercise Nine

a) $\frac{1}{4}, \frac{2}{4}, \frac{3}{4}$

b) $\frac{1}{7}, \frac{2}{7}, \frac{3}{7}, \frac{4}{7}, \frac{5}{7}, \frac{6}{7}$

c) $\frac{1}{10}, \frac{4}{10}, \frac{5}{10}, \frac{7}{10}, \frac{9}{10}$

d) $\frac{7}{361}, \frac{23}{361}, \frac{50}{361}, \frac{158}{361}, \frac{274}{361}, \frac{360}{361}$

Using a number line is another way to look at how numbers compare to each other. Fractions can also be plotted on a number line. The number line is numbered 0 to 2. The section between 0 and 1 is split into fractions.

Draw a line to connect the fractions listed to the fractions on the number line.

Example:

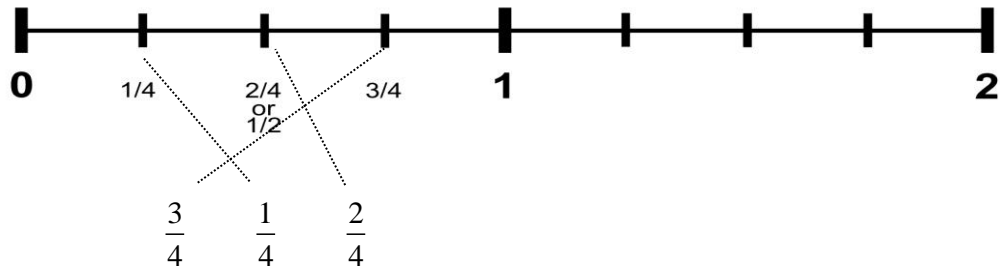

Exercise Ten

Draw a line between the following fractions and the fractions on the number line.

a)

$$\frac{2}{3} \qquad \frac{1}{3}$$

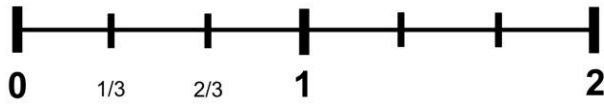

b)

$$\frac{6}{8} \quad \frac{2}{8} \quad \frac{5}{8} \quad \frac{4}{8} \quad \frac{1}{8} \quad \frac{7}{8} \quad \frac{3}{8}$$

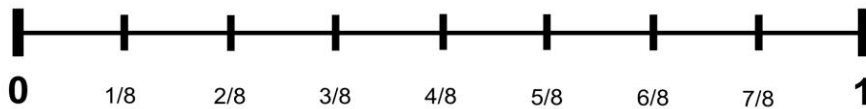

c)

$$\frac{3}{5} \quad \frac{1}{5} \quad \frac{2}{5} \quad \frac{4}{5}$$

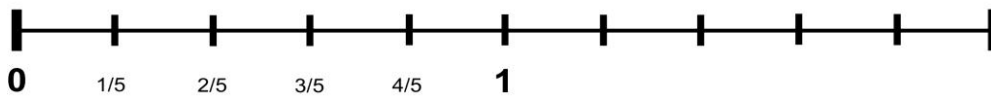

d) Complete the rule for comparing fractions. Circle the correct underlined word.

As the numerator gets bigger/smaller and the denominator stays the same, the fraction gets bigger/smaller/ stays the same.

Check your answers for exercise ten with your instructor.

Exercise Eleven

Write the fractions on the number lines in order.

a) $\frac{1}{2}, \frac{1}{4}, \frac{3}{4}$

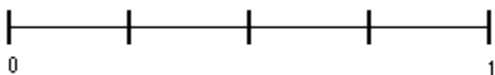

b) $\frac{2}{3}, \frac{1}{3}$

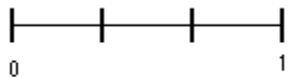

c) $\frac{3}{10}, \frac{7}{10}, \frac{5}{10}, \frac{8}{10}, \frac{1}{10}$

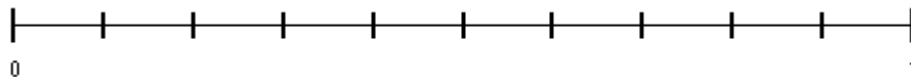

d) $\frac{5}{6}, \frac{2}{6}, \frac{3}{6}, \frac{1}{6}$

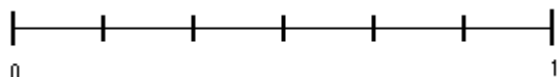

e) $\frac{7}{12}, \frac{5}{12}, \frac{3}{12}, \frac{10}{12}, \frac{1}{12}$

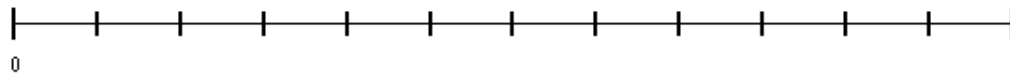

Answers to Exercise Eleven

a) $\frac{1}{4}, \frac{1}{2}, \frac{3}{4}$

b) $\frac{1}{3}, \frac{2}{3}$

c) $\frac{1}{10}, \frac{3}{10}, \frac{5}{10}, \frac{7}{10}, \frac{8}{10}, \frac{9}{10}, \frac{10}{10}$

d) $\frac{1}{6}, \frac{2}{6}, \frac{3}{6}, \frac{5}{6}$

e) $\frac{1}{12}, \frac{3}{12}, \frac{5}{12}, \frac{7}{12}, \frac{10}{12}$

Comparing Fractions with Different Denominators

You now know how to compare fractions with the same denominator, but how do you do it when the denominators of two fractions are different?

Let's look at some circles:

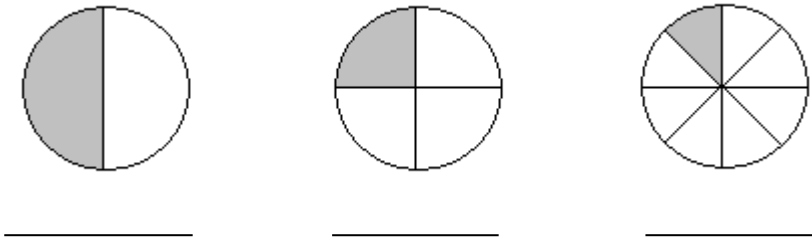

- Write a fraction for each circle above.
- Can you see that $\frac{1}{2}$ is the largest of the three fractions?

Look at the following rectangles:

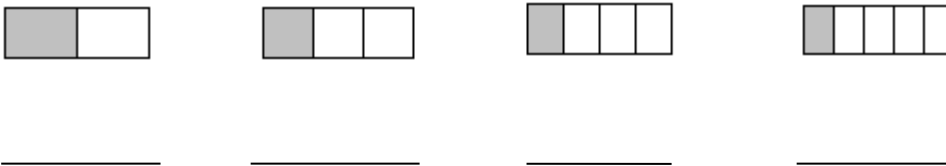

- Write a fraction for each rectangle
- Can you see which is the largest? It may be harder to see as the shaded pieces are quite close in size.

Look at the following strips:



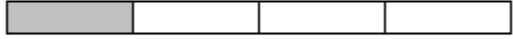

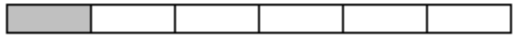

a) Write in the fraction for each shaded part.

b) Write the fractions in order from the largest to the smallest:

Check with your instructor to make sure you are on the right track.

Exercise Twelve

Look back on the last three fraction drawing sets and compare the following fractions with $<$ or $>$.

a) $\frac{1}{2}$ _____ $\frac{1}{8}$

c) $\frac{1}{6}$ _____ $\frac{1}{2}$

b) $\frac{1}{4}$ _____ $\frac{1}{3}$

d) $\frac{1}{3}$ _____ $\frac{1}{8}$

Answers to Exercise Twelve

a) $>$

b) $<$

c) $<$

d) $>$

A. Write a common fraction to describe
i) the shaded part of each whole thing
ii) the unshaded part of each whole thing

6 marks

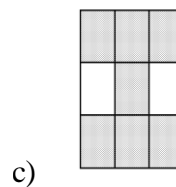
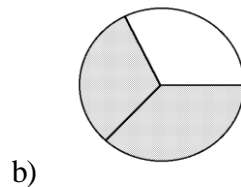
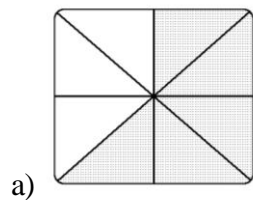

i) shaded _____ i) shaded _____ i) shaded _____
ii) unshaded _____ ii) unshaded _____ i) unshaded _____

B. Draw the following fractions.

2 marks

a. $\frac{3}{4}$

b. $\frac{1}{5}$

C. Write the word name for the following fractions.

3 marks

a. $\frac{3}{4}$ _____

b. $\frac{1}{5}$ _____

c. $\frac{3}{7}$ _____

D. Answer the question using a common fraction.

2 marks

- a) _____ The government has ordered the closing of 24 beds at the local hospital. The townspeople are angry because the hospital only has 100 beds in all. What fraction of the hospital beds are being closed?
- b) _____ The young man ordered six roses for his girlfriend. He asked for five red ones and a special yellow rose. What fraction of the roses are red?

E. Compare the following fractions, use > or <.

3 marks

a. $\frac{4}{5}$ _____ $\frac{3}{5}$

b. $\frac{12}{23}$ _____ $\frac{20}{23}$

c. $\frac{1}{3}$ _____ $\frac{2}{3}$

Answers to Self Test

A.

a. i) $\frac{5}{8}$

ii) $\frac{3}{8}$

b) i) $\frac{2}{3}$

ii) $\frac{1}{3}$

c) i) $\frac{7}{9}$

ii) $\frac{2}{9}$

B.

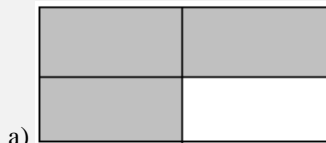

C.

a) Three quarters *or* Three fourths

b) One fifth

c) Three sevenths

D.

a) $\frac{24}{100}$

b) $\frac{5}{6}$

E.

a) >

b) <

c) <

Topic B: Common Fractions

There are three types of fractions:

- Proper fractions are part of the whole thing.
- *Improper* fractions are equal to 1 or are greater than 1.
- Mixed numbers are greater than one.

Examples:

In a **proper fraction**, the numerator is smaller than the denominator. Proper fractions are less than one.

$$\frac{3}{4} < 1$$

$$\frac{2}{5} < 1$$

$$\frac{9}{10} < 1$$

$$\frac{4}{7} < 1$$

In **improper fractions**, the numerator is the same or larger than the denominator.

$$\frac{4}{4} = 1$$

$$\frac{3}{3} = 1$$

$$\frac{8}{3} > 1$$

$$\frac{9}{7} > 1$$

In **mixed numbers**, a whole number and a proper fraction are used together.

$$1\frac{1}{2} > 1$$

$$4\frac{3}{7} > 1$$

$$3\frac{2}{5} > 1$$

$$1\frac{9}{10} > 1$$

Here are some pictures to visualize mixed numbers:

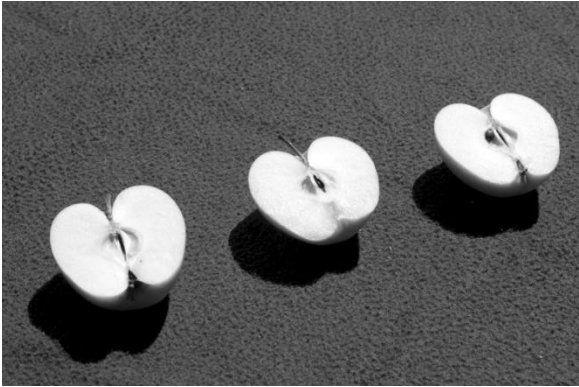

Example A:

You want to give three small children only – an apple each. You need three half apples. You can write that as – (three-halves).

How will you get $\frac{3}{2}$ of an apple?

You must use **more than one apple**. $\frac{3}{2} = 1\frac{1}{2}$ apples

This is one whole apple and $\frac{1}{2}$ of another one.



Example B:

10 pieces of pizza are shown? Each pizza was cut into 8 pieces, so the fraction can be written as $\frac{10}{8}$.

This is an **improper fraction**, it can also be written as a **mixed number** $1\frac{2}{8}$. This is 1 whole pizza, and $\frac{2}{8}$ of another one.

Exercise One



a) i) How many pieces of apple are shown?

ii) **Each** apple was cut into 4 pieces, so the denominator is

iii) Write the **improper fraction** that describes the photo.

iv) The photo shows whole apple and of a second apple.

v) Write the **mixed number** that describes the apple.

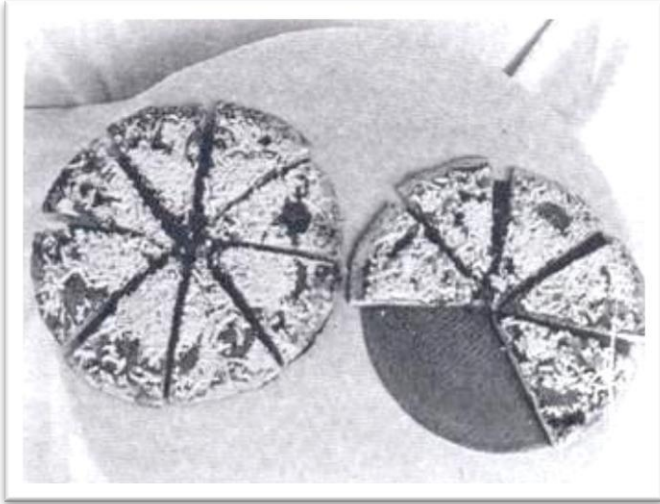

b) i) How many pieces of pizza are shown?

ii) **Each** pizza was cut into 8 pieces, so the denominator is

iii) Write the **improper fraction** that describes the photo.

iv) The photo shows whole pizza and of a second pizza.

v) Write the **mixed number** that describes the pizza.

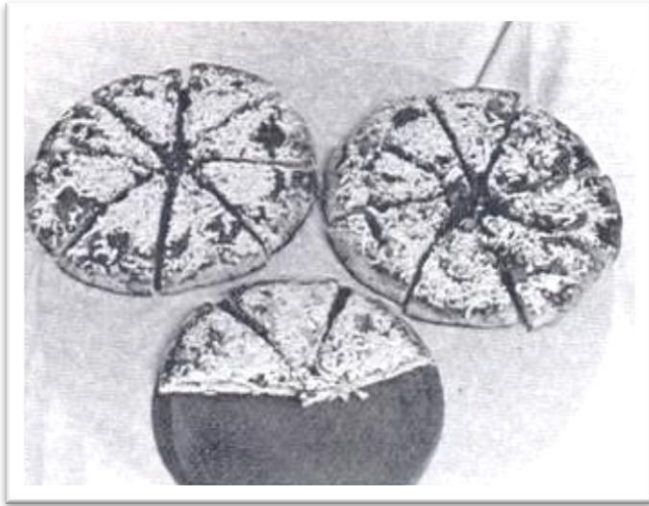

c) i) How many pieces of pizza are shown?

ii) **Each** pizza was cut into 8 pieces, so the denominator is

iii) Write the **improper fraction** that describes the photo.

iv) The photo shows whole pizzas and of a third pizza.

v) Write the **mixed number** that describes the pizza.

Answers to Exercise One

a) i) 7 ii) 4 iii) $\frac{7}{4}$ iv) 1 and $\frac{3}{4}$ v) $1\frac{3}{4}$

b) i) 13 ii) 8 iii) $\frac{13}{8}$ iv) 1 and $\frac{5}{8}$ v) $1\frac{5}{8}$

c) i) 19 ii) 8 iii) $\frac{19}{8}$ iv) 2 and $\frac{3}{8}$ v) $2\frac{3}{8}$

Exercise Two

Write the improper fraction and the mixed number that describe the shaded part in each drawing. First decide on the denominator. The denominator is what one whole thing has been divided into.

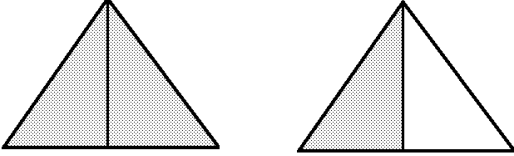
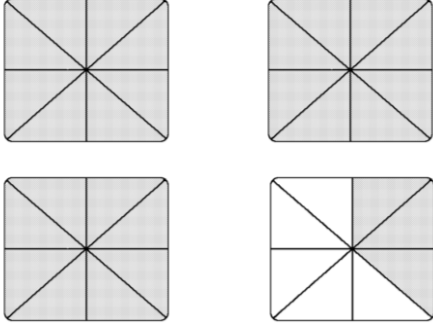
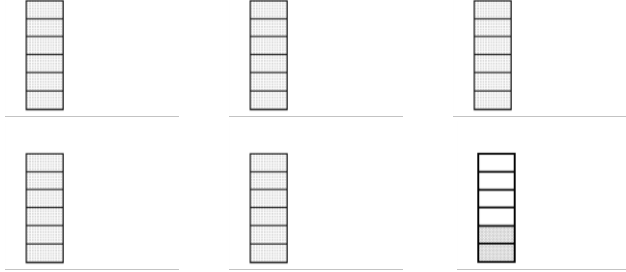
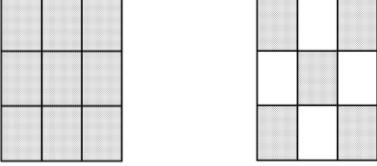
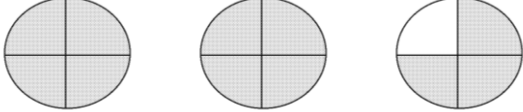
| | |
|---|--|
| <p>a) $\frac{3}{2} = 1\frac{1}{2}$</p> |  |
| <p>b)</p> |  |
| <p>c)</p> |  |
| <p>d)</p> |  |
| <p>e)</p> |  |

Answers to Exercise Two

b) $\frac{27}{8} = 3\frac{3}{8}$

c) $\frac{32}{6} = 5\frac{2}{6}$

d) $\frac{14}{9} = 1\frac{5}{9}$

e) $\frac{11}{4} = 2\frac{3}{4}$

Now it is your turn to draw some mixed numbers. Here is an example of how to do that. There are more shapes drawn here than you need (hint!)

Example:

Shade in this fraction: $4\frac{3}{4}$ (you will not need to use all the squares drawn below)

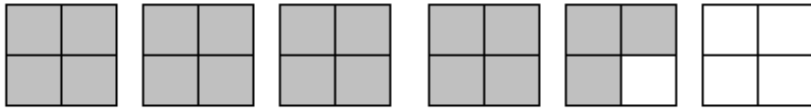

Exercise Three

Shade the following mixed fractions in the given shapes.

a) $2\frac{3}{5}$



b) $3\frac{2}{3}$

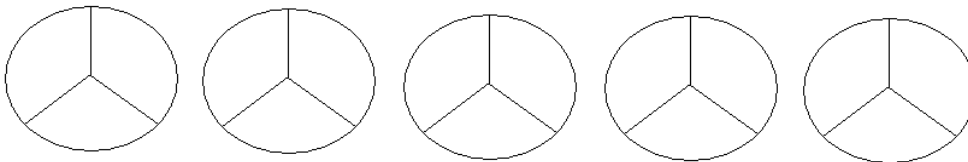

c) $5\frac{1}{4}$

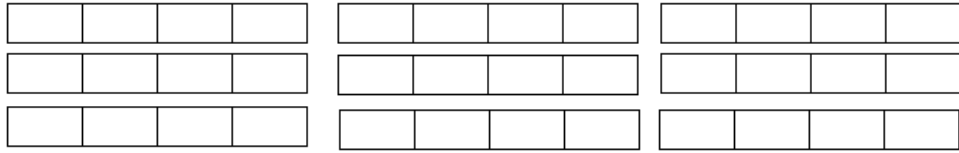

d) $1\frac{1}{2}$



Draw the following mixed fractions:

e) $4\frac{1}{2}$

f) $3\frac{4}{5}$

g) $2\frac{2}{3}$

h) $5\frac{3}{4}$

Answers to Exercise Three

a)

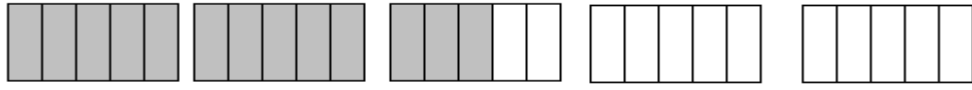

b)

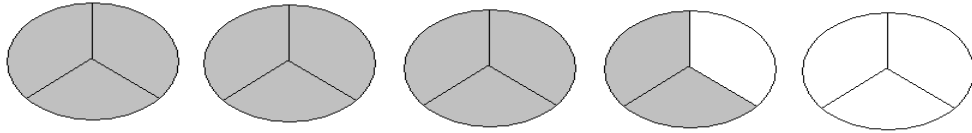

c)

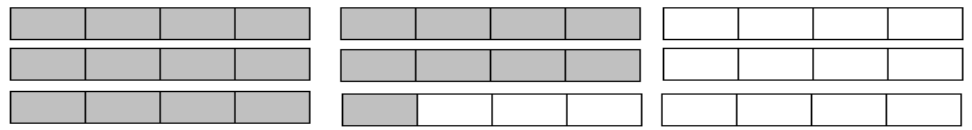

d)



e)

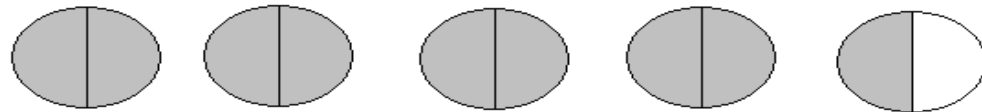

f)

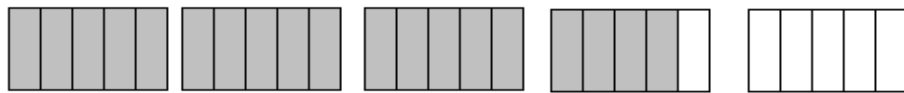



g)



h)



Writing Improper Fractions as Mixed Numbers

In the last exercise you were able to write (rename) an improper fraction as a mixed number by looking at the drawing - you could see how many whole things were represented. You could see that if the denominator was 3, every time you had $\frac{3}{3}$  that was one whole. If the denominator was 6, every time you had $\frac{6}{6}$  you had one whole, and so on.

An improper fraction is written (renamed) as a mixed number by **dividing** the **numerator** by the **number of parts in the whole** (the **denominator**).

To write (rename) an improper fraction as a mixed number, **divide** the **numerator** by the **denominator**.

Example A: $\frac{8}{5} = \square \frac{\square}{5}$

- Write as a long division problem or as a short division question.

$$\begin{array}{r} \text{denominator} \overline{) \text{ numerator}} \\ \hline \end{array} = 5 \overline{) 8}$$

$$\text{numerator} \div \text{denominator} = \square \qquad 8 \div 5 = \square$$

- Divide, write the remainder as a fraction, using the same denominator.
- The 1 becomes the whole number
- Use the remainder (3) as the numerator
- Use the divisor (5) as the denominator

$$\begin{array}{r} 1 \\ 5 \overline{) 8} \\ \hline \end{array}$$

$$\begin{array}{r} 5 \\ \hline 3 \end{array} \quad \text{or } 8 \div 5 = 1 \text{ remainder } 3$$

$$\frac{8}{5} = 1 \frac{3}{5}$$

Example B: $\frac{16}{4} = \square \frac{\quad}{4}$

$$\frac{16}{4} = 4 \overline{)16}$$

$$\begin{array}{r} 4 \overline{)16} \\ \underline{16} \\ 0 \end{array}$$

or $16 \div 4 = 4$

$$\frac{16}{4} = 4$$

Exercise Four

Rename each improper fraction as an equivalent mixed number or whole number.

a) $\frac{9}{2} = 4 \frac{1}{2}$ $\begin{array}{r} 4 \overline{)9} \\ \underline{8} \\ 1 \end{array}$

b) $\frac{12}{6} = 2$ $\begin{array}{r} 2 \overline{)12} \\ \underline{12} \\ 0 \end{array}$

c) $\frac{11}{10} = \underline{\hspace{2cm}}$

d) $\frac{12}{3} = \underline{\hspace{2cm}}$

e) $\frac{17}{6} = \underline{\hspace{2cm}}$

f) $\frac{5}{3} = \underline{\hspace{2cm}}$

g) $\frac{20}{10} = \underline{\hspace{2cm}}$

h) $\frac{12}{7} = \underline{\hspace{2cm}}$

i) $\frac{9}{5} = \underline{\hspace{2cm}}$

j) $\frac{10}{3} = \underline{\hspace{2cm}}$

k) $\frac{10}{5} = \underline{\hspace{2cm}}$

l) $\frac{14}{5} = \underline{\hspace{2cm}}$

m) $\frac{16}{8} = \underline{\hspace{2cm}}$

n) $\frac{17}{4} = \underline{\hspace{2cm}}$

o) $\frac{15}{8} = \underline{\hspace{2cm}}$

p) $\frac{4}{3} = \underline{\hspace{2cm}}$

q) $\frac{20}{4} = \underline{\hspace{2cm}}$

r) $\frac{11}{6} = \underline{\hspace{2cm}}$

s) $\frac{13}{3} = \underline{\hspace{2cm}}$

t) $\frac{13}{6} = \underline{\hspace{2cm}}$

u) $\frac{7}{4} = \underline{\hspace{2cm}}$

v) $\frac{5}{4} = \underline{\hspace{2cm}}$

w) $\frac{5}{2} = \underline{\hspace{2cm}}$

x) $\frac{10}{2} = \underline{\hspace{2cm}}$

y) $\frac{13}{8} = \underline{\hspace{2cm}}$

z) $\frac{12}{5} = \underline{\hspace{2cm}}$

| Answers to Exercise Four | | | | | |
|---------------------------------|-------------------|-------------------|-------------------|-------------------|-------------------|
| c) $1\frac{1}{10}$ | d) 4 | e) $2\frac{5}{6}$ | f) $1\frac{2}{3}$ | g) 2 | h) $1\frac{5}{7}$ |
| i) $1\frac{4}{5}$ | j) $3\frac{1}{3}$ | k) 2 | l) $2\frac{4}{5}$ | m) 2 | n) $4\frac{1}{4}$ |
| o) $1\frac{7}{8}$ | p) $1\frac{1}{3}$ | q) 5 | r) $1\frac{5}{6}$ | s) $4\frac{1}{3}$ | t) $2\frac{1}{6}$ |
| u) $1\frac{3}{7}$ | v) $1\frac{1}{4}$ | w) $2\frac{1}{2}$ | x) 5 | y) $1\frac{5}{8}$ | z) $2\frac{2}{5}$ |

Renaming Mixed Numbers as Improper Fractions

This process will be used when you multiply and divide common fractions and when you "borrow" in subtraction.

Practice Example A: Take the whole number 2.

- Here are 2 equal shapes.



- The shapes are each divided into 3 parts (thirds).



- How many thirds are there? **6** thirds.

$$2 = \frac{6}{3}$$

Practice Example B: Take the whole number 1.

- Draw one shape (a circle or a box).

- Now divide the shape into half.

- How many halves are there? _____ Halves $1 = \frac{2}{2}$

Practice **Example C:** Take the whole number 3.

- Draw 3 shapes that are the same.

- Divide each shape into fifths (5 equal parts).

- How many fifths are there in all? ____ fifths.

$$3 = \frac{\quad}{5}$$

Practice **Example D:** Take the whole number 5.

- Draw 5 shapes that are the same.

- Divide each shape into fourths (4 equal parts).

- How many fourths are there in all? ____ fourths

$$5 = \frac{\quad}{4}$$

 Ask your instructor to look at your examples.

Have you found the shortcut?

The shortcut to rename a whole number as an improper fraction is to **multiply the whole number by the denominator**.

- $2 = \frac{\quad}{4}$ Each whole number has 4 equal parts (4 quarters) in it,
so 2 (whole numbers) \times 4 (parts) = 8 parts
so $2 = \frac{8}{4}$

- $6 = \frac{\quad}{2}$ Each whole number has 2 equal parts (2 halves),
so 6 (whole numbers) \times 2 (parts) = 12 parts
so $6 = \frac{12}{2}$

- $8 = \frac{\quad}{3}$ $8 \times 3 = 24$
so $8 = \frac{24}{3}$



Until you are comfortable, draw a little sketch like you did in the example.

Exercise Five

Rename each whole number as an improper fraction using the denominator shown.

a) $6 = \frac{24}{4}$ $2 = \frac{\quad}{3}$ $4 = \frac{\quad}{3}$ $8 = \frac{\quad}{10}$

b) $1 = \frac{5}{5}$ $9 = \frac{\quad}{8}$ $3 = \frac{\quad}{4}$ $8 = \frac{\quad}{3}$

c) $1 = \frac{7}{7}$

$2 = \frac{10}{5}$

$5 = \frac{10}{2}$

$1 = \frac{8}{8}$

d) $7 = \frac{21}{3}$

$1 = \frac{4}{4}$

$6 = \frac{60}{10}$

$5 = \frac{30}{6}$

Answers to Exercise Five

a) $\frac{24}{4} \quad \frac{6}{3} \quad \frac{12}{3} \quad \frac{80}{10}$

b) $\frac{5}{5} \quad \frac{72}{8} \quad \frac{12}{4} \quad \frac{24}{3}$

c) $\frac{7}{7} \quad \frac{10}{5} \quad \frac{10}{2} \quad \frac{8}{8}$

d) $\frac{21}{3} \quad \frac{4}{4} \quad \frac{60}{10} \quad \frac{30}{6}$

Now let's take this idea further. How can you rename a **mixed number** as an improper fraction?

Practice Example A:

Take the mixed number $2\frac{1}{4}$. This is two whole things and **part of a third** whole thing.

- Here are three equal shapes divided into fourths.

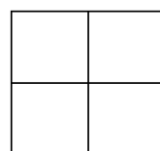
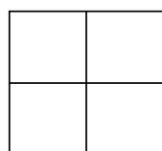
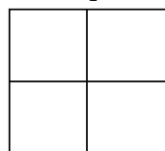

- Shade in two whole shapes $\frac{8}{4}$ and $\frac{1}{4}$ of the third shape.
- How many fourths have you shaded in all? **9** fourths

So $2\frac{1}{4} = \frac{9}{4}$

Practice Example B:

Take the mixed number $1\frac{2}{3}$. This is one whole thing and part of a second whole thing.

- Draw two equal shapes and divide them into thirds.
- Shade in 1 whole shape $\frac{3}{3}$ and $\frac{2}{3}$ of the second shape.
- How many thirds have you shaded in all? ____ thirds

$$1\frac{2}{3} = \frac{\quad}{3}$$

Practice Example C:

Take the mixed number $4\frac{4}{5}$. This is four whole things and part of a fifth whole thing.

- Draw five equal shapes and divide them into fifths.
- Shade in four whole shapes $\frac{20}{5}$ and $\frac{4}{5}$ of the fifth shape.
- How many fifths have you shaded in all? ____ fifths

$$4\frac{4}{5} = \frac{\quad}{5}$$

To **rename a mixed number as an improper fraction**, multiply the whole number by the **denominator** of the fraction and then **add this to the numerator**. Write the total as the new numerator over the denominator.

- $3\frac{1}{4} = \frac{?}{4}$

$$3 = \frac{12}{4}, \text{ so } 3\frac{1}{4} = \frac{12}{4} + \frac{1}{4} = \frac{13}{4}$$

- $2\frac{1}{2} = \frac{?}{4}$

$$2 = \frac{4}{2}, \text{ so } 2\frac{1}{2} = \frac{4}{2} + \frac{1}{2} = \frac{5}{2}$$

Exercise Six

Rename each mixed number as an improper fraction.

a) $2\frac{4}{5} = \frac{14}{5}$

$8\frac{3}{8} = \frac{\quad}{8}$

$7\frac{2}{3} = \frac{\quad}{3}$

b) $6\frac{5}{8} = \frac{53}{8}$

$5\frac{1}{2} = \frac{\quad}{2}$

$2\frac{5}{6} = \frac{\quad}{6}$

c) $8\frac{4}{5} = \underline{\hspace{2cm}}$

$6\frac{1}{8} = \underline{\hspace{2cm}}$

$7\frac{1}{3} = \underline{\hspace{2cm}}$

d) $5\frac{3}{6} = \underline{\hspace{2cm}}$

$2\frac{7}{8} = \underline{\hspace{2cm}}$

$12\frac{1}{4} = \underline{\hspace{2cm}}$

e) $1\frac{8}{10} = \underline{\hspace{2cm}}$

$3\frac{6}{8} = \underline{\hspace{2cm}}$

$4\frac{1}{5} = \underline{\hspace{2cm}}$

f) $3\frac{2}{5} = \underline{\hspace{2cm}}$

$7\frac{2}{3} = \underline{\hspace{2cm}}$

$4\frac{3}{4} = \underline{\hspace{2cm}}$

Answers to Exercise Six

a) $\frac{14}{5}$ $\frac{67}{8}$ $\frac{23}{3}$

b) $\frac{53}{8}$ $\frac{11}{2}$ $\frac{17}{6}$

c) $\frac{44}{5}$ $\frac{49}{8}$ $\frac{22}{3}$

d) $\frac{33}{6}$ $\frac{23}{8}$ $\frac{49}{4}$

e) $\frac{18}{10}$ $\frac{30}{8}$ $\frac{21}{5}$

f) $\frac{17}{5}$ $\frac{23}{3}$ $\frac{19}{4}$

To Say or Write a Mixed Number

If you want to say these crazy looking fractions out loud, you do as follows:

Write or say:

1) the whole number

2) and

3) the fraction

Example: $3\frac{2}{5}$ = three and two fifths

$5\frac{1}{6}$ = five and one sixth

Exercise Seven

Write the following fractions as words.

a) $2\frac{1}{8}$ _____

b) $4\frac{3}{4}$ _____

c) $1\frac{1}{2}$ _____

d) $3\frac{3}{4}$ _____

e) $7\frac{3}{8}$ _____

f) $8\frac{4}{5}$ _____

g) $9\frac{3}{8}$ _____

h) $2\frac{5}{6}$ _____

i) $12\frac{1}{4}$ _____

Answers to Exercise Seven

- a) two and one eighths
- b) four and three fourths (or four and three quarters)
- c) one and one half
- d) three and three fourths (or three and three quarters)
- e) seven and three eighths
- f) eight and four fifths
- g) nine and three eighths
- h) two and five sixths
- i) twelve and one fourth (or twelve and one quarter)

Topic B Self-Test

Mark /16

Aim 13/16

A. Write the improper fraction and the mixed number that describe the shaded part of the drawings in each question.

4 marks

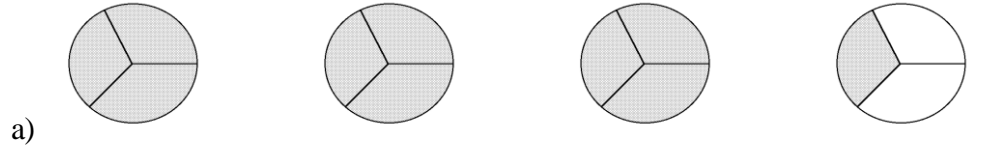

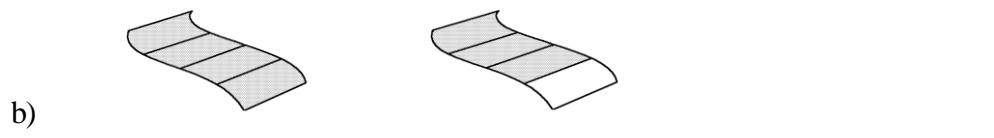

B. Rename each improper fraction as an equivalent mixed number or whole number.

6 marks

a) $\frac{9}{4} =$ _____

b) $\frac{12}{3} =$ _____

c) $\frac{22}{5} =$ _____

d) $\frac{3}{2} =$ _____

e) $\frac{5}{3} =$ _____

f) $\frac{7}{2} =$ _____

C. Rename as improper fractions.

6 marks

a) $3\frac{1}{2} =$ _____

b) $4\frac{3}{8} =$ _____

c) $5\frac{3}{4} =$ _____

d) $1 = \frac{?}{2} =$ _____

e) $1\frac{7}{8} =$ _____

f) $2\frac{5}{6} =$ _____

Answers to Topic B Self Test

A.

a) $\frac{10}{3} = 3\frac{1}{3}$

b) $\frac{7}{4} = 1\frac{3}{4}$

B.

a) $2\frac{1}{4}$

b) 4

c) $4\frac{2}{5}$

d) $1\frac{1}{2}$

e) $1\frac{2}{3}$

f) $3\frac{1}{2}$

C.

a) $\frac{7}{2}$

b) $\frac{35}{8}$

c) $\frac{23}{4}$

d) $1 = \frac{2}{2}$

e) $\frac{15}{8}$

f) $\frac{17}{6}$

Topic C: When to Use a Fraction or a Decimal

Sometimes you need to decide to write or say a number as a fraction or a decimal. We usually choose the most common method, which is usually the easiest way to say something. It may seem to you that nothing is easy at this moment, so here are some tips.

When we talk about money, we almost always talk about a part of a dollar.

Example: Two dollars and fifteen cents is two whole dollars and fifteen parts of one more dollar.

\$2.15 or $\$2\frac{15}{100}$ which of these ways of writing money is more common, or easy to you?

We usually write or talk about money in decimals:

Example 1: \$2.50 (two dollars and fifty cents) instead of $\$2\frac{1}{2}$ (two and a half dollars)

Example 2: \$0.50 (fifty cents) instead of $\$\frac{1}{2}$ (half a dollar)

Example 3: \$67.30 (sixty seven dollars and thirty cents) instead of $\$67\frac{30}{100}$ (sixty seven dollars and thirty hundredths cents)

But: There is one place where we talk about money as a fraction: The quarter!

A quarter equals \$0.25, but we often say “it costs a quarter” as much as we say “it costs 25 cents”.

Really, if we were speaking correctly, it would be a quarter of a dollar, but it gets shortened.

Also, we still write \$0.25 or 25¢, not $\$\frac{25}{100}$ or $\$\frac{1}{4}$.

In most other ways of talking and writing, fractions and decimals are expressed in what seems easiest. This means that you get to say the number in the way you like best.

Example: Saying six point four grams may be faster and easier than saying six and two fifths grams.

But, saying $\frac{3}{4}$ of a tank of gas makes more sense than saying 0.75 of a tank of gas.

Exercise One

Circle the way that you think a number should be said out loud.
(read the numbers out loud with a friend to help hear them)
Remember, that sometimes your answers will be different from the ones in the answer key because you have a different opinion, and that it O.K.

| | | | |
|----|--|----|---------------------------------|
| a) | \$12.25 | or | $\$12\frac{1}{4}$ |
| b) | 51.4 cm | or | $51\frac{2}{5}$ cm |
| c) | One million two hundred thousand dollars | or | One point two million dollars |
| d) | 563.56 km | or | $563\frac{56}{100}$ km |
| e) | $5\frac{7}{10}$ L | or | 5.7 L |
| f) | I ran a tenth of a kilometer | or | I ran zero point one kilometers |
| g) | It weighs five and a half grams | or | It weighs five point five grams |
| h) | $\$39\frac{99}{100}$ | or | \$39.99 |

Answers to Exercise One

- | | | |
|--------------|------------|----------------------------------|
| a) \$12.25 | b) 51.4 cm | c) One point two million dollars |
| d) 563.56 km | e) 5.7 L | f) I ran a tenth of a kilometer |
| g) both | h) \$39.99 | |

Unit One Review

1. Write fractions from the pictures

a)

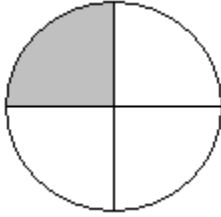

b)

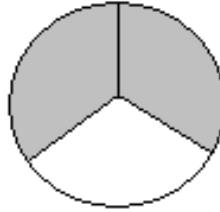

c)

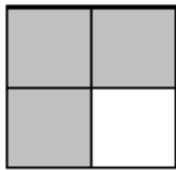

d)



e)

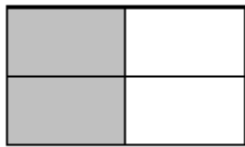

f)



1. Draw your own fractions:

a) $\frac{2}{5}$

b) $\frac{1}{4}$

c) $\frac{4}{9}$

d) $\frac{1}{6}$

e) $\frac{1}{3}$

f) $\frac{7}{10}$

2. Write the following fractions in words:

a) $\frac{1}{2}$ one half _____

b) $\frac{1}{4}$ one quarter _____

c) $\frac{3}{4}$ _____

d) $\frac{2}{5}$ _____

e) $\frac{4}{9}$ _____

f) $\frac{2}{3}$ _____

g) $\frac{7}{10}$ _____

h) $\frac{21}{25}$ _____

i) $\frac{1}{3}$ _____

j) $\frac{5}{6}$ _____

3. Answer the questions using a common fraction:

- a) Suzie jogged 20 minutes out of 1 hour. What fraction of the hour did she jog?
(remember 1 hour = 60 minutes)

- b) Oliver planted 30 garlic cloves in September. 25 shoots have come up in the spring.
What fractions of garlic bulbs did not grow a shoot?

- c) The class usually had 8 students, but 6 did not come on Monday. What fraction of students did not come?

- d) Stephen made 60 Easter cookies. His brother ate 3, his mom ate 3 more. What fraction of cookies were eaten by Stephen's family?

- e) Thrifty's grocery store sold 300 dozen eggs in one week. They had 450 dozen in stock. What fraction of the stock was sold?

f) The test was out of 32. Sasha got 30 marks. What was her score?

4. Compare the following fractions:

a) $\frac{3}{4}$ _____ $\frac{1}{4}$

b) $\frac{9}{10}$ _____ $\frac{3}{10}$

c) $\frac{1}{5}$ _____ $\frac{3}{5}$

d) $\frac{3}{8}$ _____ $\frac{7}{8}$

e) seven tenths _____ three tenths

f) one quarter _____ three quarters

g) four fifths _____ three fifths

h) one twelfth _____ eleven twelfths

6. Identify each fraction by writing: **proper fraction**, **improper fraction**, or **mixed number** next to each fraction.

a) $\frac{1}{2}$ _____

b) $\frac{3}{2}$ _____

c) $\frac{100}{47}$ _____

d) $1\frac{3}{7}$ _____

e) $\frac{5}{6}$ _____

f) $3\frac{1}{4}$ _____

g) $\frac{51}{2}$ _____

h) $\frac{1}{3}$ _____

i) $42\frac{1}{4}$ _____

j) $\frac{4}{3}$ _____

7. Fill in the missing parts of the chart:

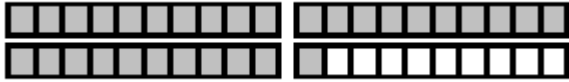
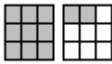
| | Improper Fraction | Mixed Number | Drawing |
|----|-------------------|----------------|---|
| a) | | |  |
| b) | $\frac{29}{6}$ | | |
| c) | | $2\frac{3}{4}$ | |
| d) | | |  |
| e) | $\frac{9}{2}$ | | |
| f) | | $3\frac{1}{5}$ | |
| g) | | |  |
| h) | $\frac{25}{8}$ | | |
| i) | | $3\frac{1}{3}$ | |

8. Rename each proper fraction into a mixed number or a whole number.

a) $\frac{9}{5} = \underline{\hspace{2cm}}$

b) $\frac{7}{2} = \underline{\hspace{2cm}}$

c) $\frac{11}{2} = \underline{\hspace{2cm}}$

d) $\frac{14}{5} = \underline{\hspace{2cm}}$

e) $\frac{4}{3} = \underline{\hspace{2cm}}$

f) $\frac{11}{6} = \underline{\hspace{2cm}}$

g) $\frac{14}{3} = \underline{\hspace{2cm}}$

h) $\frac{10}{2} = \underline{\hspace{2cm}}$

i) $\frac{13}{5} = \underline{\hspace{2cm}}$

j) $\frac{11}{8} = \underline{\hspace{2cm}}$

k) $\frac{6}{6} = \underline{\hspace{2cm}}$

l) $\frac{5}{4} = \underline{\hspace{2cm}}$

m) $\frac{7}{3} = \underline{\hspace{2cm}}$

n) $\frac{8}{4} = \underline{\hspace{2cm}}$

9. Rename each whole number as an improper fraction. Use the denominator given to you.

a) $6 = \frac{\hspace{1cm}}{3}$

b) $5 = \frac{\hspace{1cm}}{2}$

c) $3 = \frac{\hspace{1cm}}{7}$

d) $4 = \frac{\hspace{1cm}}{5}$

e) $1 = \frac{\hspace{1cm}}{1}$

f) $9 = \frac{\hspace{1cm}}{2}$

g) $7 = \frac{\hspace{1cm}}{3}$

h) $8 = \frac{\hspace{1cm}}{7}$

i) $1 = \frac{\hspace{1cm}}{3}$

j) $2 = \frac{\hspace{1cm}}{10}$

10. Rename each mixed number as an improper fraction.

a) $6\frac{7}{8} = \underline{\hspace{2cm}}$

b) $2\frac{1}{2} = \underline{\hspace{2cm}}$

c) $15\frac{4}{5} = \underline{\hspace{2cm}}$

d) $2\frac{1}{3} = \underline{\hspace{2cm}}$

e) $9\frac{9}{10} = \underline{\hspace{2cm}}$

f) $4\frac{1}{6} = \underline{\hspace{2cm}}$

g) $20\frac{3}{7} = \underline{\hspace{2cm}}$

h) $18\frac{1}{2} = \underline{\hspace{2cm}}$

i) $5\frac{9}{11} = \underline{\hspace{2cm}}$

j) $3\frac{1}{4} = \underline{\hspace{2cm}}$

Answers to Review

1.

- a. $\frac{1}{4}$ b. $\frac{2}{3}$ c. $\frac{3}{4}$ d. $\frac{1}{2}$ e. $\frac{2}{4}$ f. $\frac{4}{6}$

2.

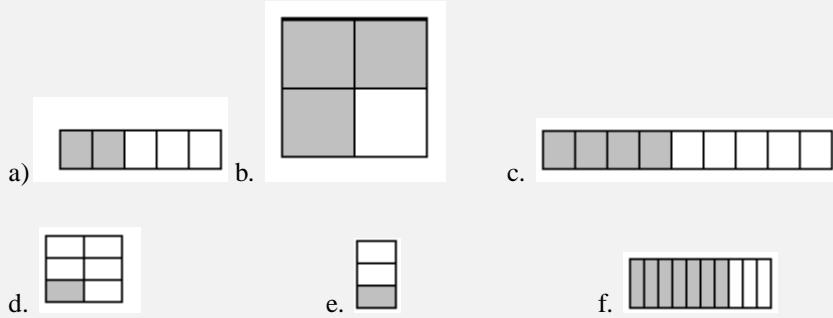

3.

- a) One half
- b) One fourth or one quarter
- c) Three fourths of three quarters
- d) Two fifths
- e) Four ninths
- f) Two thirds
- g) Seven tenths
- h) Twenty one twenty fifths
- i) One third
- j) Five sixths

4.

- a) $\frac{20}{60}$ b) $\frac{5}{30}$ c) $\frac{6}{8}$ d) $\frac{6}{60}$ e) $\frac{300}{450}$ f) $\frac{30}{32}$

5.

- a) > b) > c) < d) < e) > f) <
- g) > h) <

6.

- a) proper fraction b) improper fraction c) improper fraction d) mixed number
- e) proper fraction f) mixed number g) improper fraction h) proper fraction
- i) mixed number j) improper fraction

7.

| | Improper Fraction | Mixed Number | Drawing |
|---|-------------------|-----------------|---------|
| a | $\frac{11}{3}$ | $3\frac{2}{3}$ | |
| b | $\frac{29}{6}$ | $4\frac{5}{6}$ | |
| c | $\frac{11}{4}$ | $2\frac{3}{4}$ | |
| d | $\frac{31}{10}$ | $3\frac{1}{10}$ | |
| e | $\frac{9}{2}$ | $4\frac{1}{2}$ | |
| f | $\frac{16}{5}$ | $3\frac{1}{5}$ | |
| g | $\frac{11}{9}$ | $1\frac{2}{9}$ | |
| h | $\frac{25}{8}$ | $3\frac{1}{8}$ | |
| i | $\frac{10}{3}$ | $3\frac{1}{3}$ | |

8.

- a) $1\frac{4}{5}$ b) $3\frac{1}{2}$ c) $5\frac{1}{2}$ d) $2\frac{4}{5}$ e) $1\frac{1}{3}$ f) $1\frac{5}{6}$ g) $4\frac{2}{3}$
- h) 5 i) $2\frac{3}{5}$ j) $1\frac{3}{8}$ k) 1 l) $1\frac{1}{4}$ m) $2\frac{1}{3}$ n) 2

9.

- a) $\frac{18}{3}$ b) $\frac{10}{2}$ c) $\frac{21}{7}$ d) $\frac{20}{5}$ e) $\frac{1}{1}$ f) $\frac{18}{2}$
- g) $\frac{21}{3}$ h) $\frac{56}{7}$ i) $\frac{3}{3}$ j) $\frac{20}{10}$

10.

- a) $\frac{55}{8}$ b) $\frac{5}{2}$ c) $\frac{79}{5}$ d) $\frac{7}{3}$ e) $\frac{99}{10}$ f) $\frac{25}{6}$
- g) $\frac{143}{7}$ h) $\frac{37}{2}$ i) $\frac{64}{11}$ j) $\frac{13}{4}$

It is now test time!

Please get the practice test
from your instructor.

Once you are ready, you can get
the unit 1 test from your instructor.

Good luck!

Unit 2

Equivalent Fractions

Topic A: Equivalent Fractions

Start from the left side of each drawing and shade in the fraction shown.



This shape is the whole thing.



Shade $\frac{1}{2}$



Shade $\frac{2}{4}$

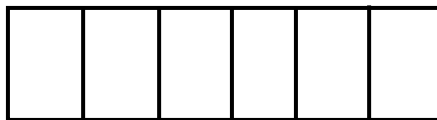

Shade $\frac{3}{6}$



Shade $\frac{4}{8}$



Shade $\frac{5}{10}$

Did you notice that the amount you shaded was the same in each drawing?

The fractions that you were asked to shade are **equivalent fractions**. Equivalent fractions **are fractions that are equal to each other**.

Now shade the fractions asked for in these drawings.



This shape is the whole thing.



Shade $\frac{1}{3}$

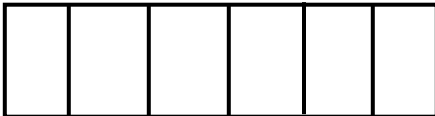

Shade $\frac{2}{6}$



Shade $\frac{3}{9}$



Shade $\frac{4}{12}$

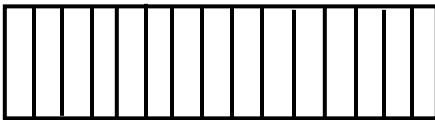

Shade $\frac{5}{15}$

These above examples are all equivalent fractions. $\frac{1}{3} = \frac{2}{6} = \frac{3}{9} = \frac{4}{12} = \frac{5}{15}$



To work with common fractions, it is **often necessary** to **use an equivalent fraction** in place of the fraction that is given. There are several processes to learn which will help you to find equivalent fractions.

Factors

Factors are the **numbers which are multiplied together to make a product**. An understanding of factors is needed to express fractions in lowest terms.

Example A:

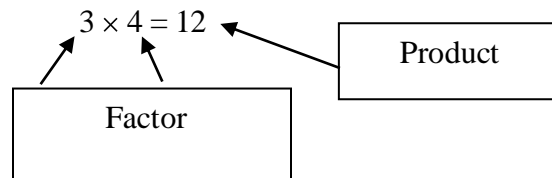

We say, "The factors of 12 are 3 and 4."

Does 12 have any other factors?

What other numbers can be multiplied together to equal 12?

$$1 \times 12 = 12 \quad \text{or} \quad 12 \times 1 = 12$$

$$2 \times 6 = 12 \quad \text{or} \quad 6 \times 2 = 12$$

$$3 \times 4 = 12 \quad \text{or} \quad 4 \times 3 = 12$$

The factors of 12 are 1, 2, 3, 4, 6, 12.

Example B: Find the factors of 10.

$$1 \times 10 = 10$$

$$2 \times 5 = 10$$

The factors of 10 are 1, 2, 5, 10.

Example C: Find the factors of 9.

$$1 \times 9 = 9$$

$$3 \times 3 = 9$$

The factors of 9 are 1, 3, 9.

Example D: Find the factors of 18.

$$1 \times 18 = 18$$

$$2 \times 9 = 18$$

$$3 \times 6 = 18$$

The factors of 18 are 1, 2, 3, 6, 9, 18.

Exercise One

Find all the factors.

a) The factors of 16: $1 \times 16 = 16$; $2 \times 8 = 16$; $4 \times 4 = 16$
The factors of 16 are 1, 2, 4, 8, 16.

b) The factors of 4: $1 \times 4 = 4$; $2 \times 2 = 4$
The factors of 4 are 1, 2, 4.

c) The factors of 8: _____

d) The factors of 20: _____

e) The factors of 5: _____

f) The factors of 15: _____

g) The factors of 21: _____

h) The factors of 6: _____

i) The factors of 25: _____

j) The factors of 14: _____

k) The factors of 7: _____

l) The factors of 100: _____

Answers to Exercise One

c) 1, 2, 4, 8

d) 1, 2, 4, 5, 10, 20

e) 1, 5

f) 1, 3, 5, 15

g) 1, 3, 7, 21

h) 1, 2, 3, 6

i) 1, 5, 25

j) 1, 2, 7, 14

k) 1, 7

l) 1, 2, 4, 5, 10, 20, 25, 50, 100

Some numbers **only have two factors, 1 and the number itself**. These numbers are called **prime numbers**. Look at the chart for some prime numbers.

| Prime number | Factors |
|---------------------|----------------|
| 1 | 1, 1 |
| 2 | 1, 2 |
| 3 | 1, 3 |
| 5 | 1, 5 |
| 7 | 1, 7 |
| 11 | 1, 11 |
| 13 | 1, 13 |
| 17 | 1, 17 |
| 19 | 1, 19 |
| 23 | 1, 23 |
| 29 | 1, 29 |
| | |
| | |
| | |
| | |
| | |

Add other prime numbers to the chart as you find them.

Reminder: Prime numbers only have _____ factors.

Finding Common Factors

A **common factor** is a number used to reduce the numerator and denominator.

Example A: What are the common factors for $\frac{4}{6}$?

- Find the factors of 4 and 6.
 - The factors of 4 are 1, 2, 4.
 - The factors of 6 are 1, 2, 3, 6.
- What factors do 4 and 6 have in common?

4: 1, 2, 4
6: 1, 2, 3, 6

- The common factors of 4 and 6 are **1 and 2**

We do not use 1 as a **common factor**. 1 is a factor of all **whole numbers**.

Example B: What are the common factors of $\frac{6}{15}$?

- Find the factors of 6 and 15.
 - The factors of 6 are 1, 2, 3, 6.
 - The factors of 15 are 1, 3, 5, 15.
- What factors do 6 and 15 have in common?

6: 1, 2, 3, 6
15: 1, 3, 5, 15

- The common factor of 6 and 15 is **3**.

Example C: Find the common factors of $\frac{16}{24}$.

- The factors of 16 are 1, 2, 4, 8, 16
- The factors of 24 are 1, 2, 3, 4, 6, 8, 12, 24
- The common factors of 16 and 24 are: 2, 4, 8

8 is called the **greatest common factor (GCF)** of 16 and 24 because it is the largest of all the common factors.

Exercise Two

Find the common factors. Write the greatest common factor in the last column.

| | Factors | Common Factors | Greatest Common Factor |
|-----------|--|-----------------------|-------------------------------|
| a) 10, 15 | <i>...of 10 are 1, 2, 5, 10</i> <i>...of 15 are 1, 3, 5, 15</i> | 5 | 5 |
| b) 4, 16 | <i>...of 4 are 1, 2, 4</i> <i>...of 16 are 1, 2, 4, 8, 16</i> | 2, 4 | 4 |
| c) 9, 12 | | | |
| d) 20, 30 | | | |
| e) 18, 12 | | | |
| f) 24, 32 | | | |
| g) 8, 12 | | | |
| h) 6, 9 | | | |
| i) 9, 15 | | | |
| j) 14, 21 | | | |
| k) 15, 25 | | | |
| l) 6, 8 | | | |

Answers to Exercise Two

| | Factors | Common Factors | Greatest Common Factor |
|-----------|---|-----------------------|-------------------------------|
| a) 10, 15 | ... of 10 are 1, 2, 5, 10 ... of 15 are 1, 3, 5, 15 | 5 | 5 |
| b) 4, 16 | ... of 4 are 1, 2, 4 ... of 16 are 1, 2, 4, 8, 16 | 2, 4 | 4 |
| c) 9, 12 | ... of 9 are 1, 3, 9 ... of 12 are 1, 2, 3, 4, 6, 12 | 3 | 3 |
| d) 20, 30 | ... of 20 are 1, 2, 4, 5, 10, 20 ... of 30 are 1, 2, 3, 5, 6, 10, 15, 30 | 2, 5, 10 | 10 |
| e) 18, 12 | ... of 18 are 1, 2, 3, 6, 9, 18 ... of 12 are 1, 2, 3, 4, 6, 12 | 2, 3, 6 | 6 |
| f) 24, 32 | ... of 24 are 1, 2, 3, 4, 6, 8, 12, 24 ... of 32 are 1, 2, 4, 8, 16, 32 | 2, 4, 8 | 8 |
| g) 8, 12 | ... of 8 are 1, 2, 4, 8 ... of 12 are 1, 2, 3, 4, 6, 12 | 2, 4 | 4 |
| h) 6, 9 | ... of 6 are 1, 2, 3, 6 ... of 9 are 1, 3, 9 | 3 | 3 |
| i) 9, 15 | ... of 9 are 1, 3, 9 ... of 15 are 1, 3, 5, 15 | 3 | 3 |
| j) 14, 21 | ... of 14 are 1, 2, 7, 14 ... of 21 are 1, 3, 7, 21 | 7 | 7 |
| k) 15, 25 | ... of 15 are 1, 3, 5, 15 ... of 25 are 1, 5, 25 | 5 | 5 |
| l) 6, 8 | ... of 6 are 1, 2, 3, 6 ... of 8 are 1, 2, 4, 8 | 2 | 2 |

Expressing Fractions in Lower Terms

Express means to **say it or write it**.

Lower terms means to express equivalent fractions with smaller (lower) denominators.

Look back to the first page of unit 2. The equivalent fraction in lowest terms is $\frac{1}{2}$.

The words **simplify and reduce** are another way to say “**express fractions in lower (or lowest) terms**”.

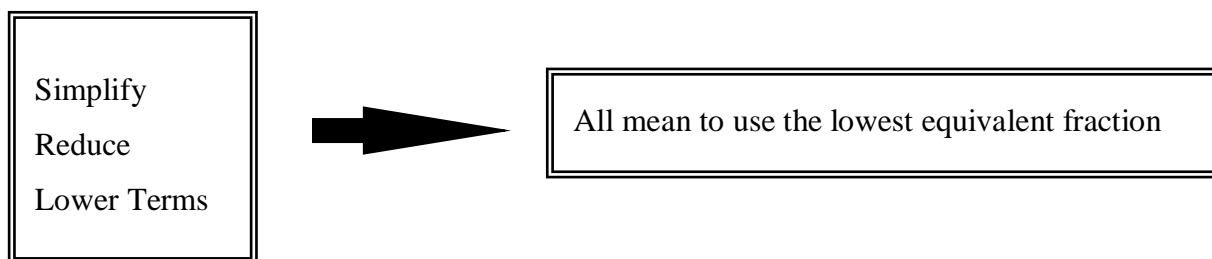

To express a fraction in lowest terms, do this:

Step 1: Find the greatest common factor (GCF) of the numerator and denominator

$$\frac{4}{12}$$

The factors of 4 are 1, 2, 4
The factors of 12 are 1, 2, 3, 4, 6, 12

The GCF is 4.

Step 2: Divide the numerator and the denominator by the greatest common factor.

$$\frac{4}{12} \div 4 = \frac{1}{3}$$

$$\frac{4}{12} = \frac{1}{3}$$

Example A:

$$\frac{6}{9}$$

The factors of 6 are 1, 2, 3, 6.

The factors of 9 are 1, 3, 9.

The GCF is 3.

$$\frac{6 \div 3}{9 \div 3} = \frac{2}{3}$$

$$\frac{6}{9} = \frac{2}{3}$$

Example B:

$$\frac{15}{24}$$

The factors of 15 are 1, 3, 5, 15.

The factors of 24 are 1, 2, 3, 4, 6, 8, 24.

The GCF is 3.

$$\frac{15 \div 3}{24 \div 3} = \frac{5}{8}$$

$$\frac{15}{24} = \frac{5}{8}$$

Use lower terms for several reasons:

- The math is usually easier with lower numbers.
- Is it easier to think of $\frac{1}{2}$ an apple **or** $\frac{15}{30}$ of an apple? ($\frac{1}{2} = \frac{15}{30}$)
- Do you want to think about $\frac{155}{620}$ of your pay cheque **or** $\frac{1}{4}$ of your pay cheque? ($\frac{1}{4} = \frac{155}{620}$)
- Always express fractions in lowest terms!

Dividing both the numerator and denominator **by the GCF** will give an equivalent fraction in lower terms.

Exercise Three

Express each fraction in lowest terms. (The directions could also say, "Simplify each fraction," or "Reduce these fractions").

a) $\frac{2}{4} \div \frac{2}{2} = \frac{1}{2}$

$\frac{3}{9} \div =$ _____

b) $\frac{2}{12} \div \frac{2}{2} = \frac{1}{6}$

$\frac{3}{15} \div =$ _____

c) $\frac{5}{10} \div =$ _____

$\frac{4}{24} \div =$ _____

d) $\frac{10}{25} \div =$ _____

$\frac{9}{12} \div =$ _____

Make sure that you write in the GCF you are dividing with. Do not skip this step until you are totally sure you can do it correctly in your head each time.

(Good mathematicians know when to skip steps and when not to... sometimes easy steps are never skipped by good mathematicians).

e) $\frac{3}{30} =$ _____

$\frac{6}{10} =$ _____

f) $\frac{9}{24} =$ _____

$\frac{18}{27} =$ _____

g) $\frac{4}{16} =$ _____

$\frac{3}{12} =$ _____

h) $\frac{15}{24} =$ _____

$\frac{12}{32} =$ _____

i) $\frac{2}{32} =$ _____

$\frac{6}{20} =$ _____

j) $\frac{21}{24} = \underline{\hspace{2cm}}$

$\frac{10}{15} = \underline{\hspace{2cm}}$

k) $\frac{10}{14} = \underline{\hspace{2cm}}$

$\frac{16}{32} = \underline{\hspace{2cm}}$

l) $\frac{15}{25} = \underline{\hspace{2cm}}$

$\frac{12}{28} = \underline{\hspace{2cm}}$

m) $\frac{2}{16} = \underline{\hspace{2cm}}$

$\frac{2}{20} = \underline{\hspace{2cm}}$

n) $\frac{10}{16} = \underline{\hspace{2cm}}$

$\frac{6}{9} = \underline{\hspace{2cm}}$

o) $\frac{10}{30} = \underline{\hspace{2cm}}$

$\frac{3}{18} = \underline{\hspace{2cm}}$

p) $\frac{6}{24} = \underline{\hspace{2cm}}$

$\frac{8}{16} = \underline{\hspace{2cm}}$

q) $\frac{14}{24} = \underline{\hspace{2cm}}$

$\frac{6}{18} = \underline{\hspace{2cm}}$

r) $\frac{10}{18} = \underline{\hspace{2cm}}$

$\frac{6}{36} = \underline{\hspace{2cm}}$

Answers to Exercise Three

a) $\frac{1}{2}, \frac{1}{3}$

b) $\frac{1}{6}, \frac{1}{5}$

c) $\frac{1}{2}, \frac{1}{6}$

d) $\frac{2}{5}, \frac{3}{4}$

e) $\frac{1}{10}, \frac{3}{5}$

f) $\frac{3}{8}, \frac{2}{3}$

g) $\frac{1}{4}, \frac{1}{4}$

h) $\frac{5}{8}, \frac{3}{8}$

i) $\frac{1}{16}, \frac{3}{10}$

j) $\frac{7}{8}, \frac{2}{3}$

k) $\frac{5}{7}, \frac{1}{2}$

l) $\frac{3}{5}, \frac{3}{7}$

m) $\frac{1}{8}, \frac{1}{10}$

n) $\frac{5}{8}, \frac{2}{3}$

o) $\frac{1}{3}, \frac{1}{6}$

p) $\frac{1}{4}, \frac{1}{2}$

q) $\frac{7}{12}, \frac{1}{3}$

r) $\frac{5}{9}, \frac{1}{6}$

Expressing Fractions in Higher Terms

Higher Terms are needed when you add and subtract fractions with different denominators.

You have learned that **dividing** both the numerator and denominator of a fraction by a common factor **gives an equivalent fraction in lower terms**. You know that dividing and multiplying are opposite operations, so this next rule will match the one you just learned for reducing:

Multiplying both the numerator and denominator of a fraction by the same number (a **common factor**) will give an **equivalent fraction in higher terms**.

Example A:

$$\frac{3}{5} \left(\frac{\times 2}{\times 2} \right) = \frac{6}{10} \qquad \frac{3}{5} = \frac{6}{10}$$

Example B:

$$\frac{1}{2} \left(\frac{\times 8}{\times 8} \right) = \frac{8}{16} \qquad \frac{1}{2} = \frac{8}{16}$$

Example C:

$$\frac{2}{3} \left(\frac{\times 2}{\times 2} \right) = \frac{6}{9} \qquad \frac{2}{3} = \frac{6}{9}$$

Are the Fractions Equivalent?

If the denominators are the same, you can easily judge if the fractions are equivalent by comparing the numerators

$$\text{Compare } \frac{4}{5} \text{ and } \frac{3}{5}: \quad \frac{4}{5} \neq \frac{3}{5} \quad (\neq \text{ means 'not equal'})$$

$$\text{Compare } \frac{12}{20} \text{ and } \frac{12}{20}: \quad \frac{12}{20} = \frac{12}{20}$$

If the denominators are different, you **might be able to rewrite one or more of the fractions so they have the same denominator.**

$$\text{Compare } \frac{4}{5} \text{ and } \frac{6}{10}: \quad \frac{6}{10} \div 2 = \frac{3}{5} \quad \text{So: } \frac{4}{5} \neq \frac{3}{5}$$

$$\text{Compare } \frac{12}{16} \text{ and } \frac{5}{8}: \quad \frac{5}{8} \times 2 = \frac{10}{16} \quad \text{So: } \frac{12}{16} \neq \frac{10}{16}$$

$$\text{or you could do this: } \quad \frac{12}{16} \div 2 = \frac{6}{8} \quad \text{So: } \frac{6}{8} \neq \frac{5}{8}$$

A quick method is to **cross multiply**:

1. multiply the numerator of one fraction by the denominator of the second fraction
2. multiply the numerator of the **other** fraction by the denominator of the **first** fraction

These are called the *cross-products*.

If the cross products are the same, then the fraction is equivalent

Look at the examples:

Example A: Compare $\frac{4}{7}$ and $\frac{5}{9}$

$$\frac{4}{7} \quad \begin{array}{c} \nearrow \\ \searrow \end{array} \quad \frac{5}{9}$$

Multiply numerator 4 by denominator 9 $4 \times 9 = 36$

Multiply denominator 7 by numerator 5 $7 \times 5 = 35$

The products 36 and 35 **are not** the same.

Therefore $\frac{4}{7} \neq \frac{5}{9}$

Example B: Compare $\frac{2}{3}$ and $\frac{12}{18}$

$$\frac{2}{3} \quad \begin{array}{c} \nearrow \\ \searrow \end{array} \quad \frac{12}{18}$$

$$2 \times 18 = 36$$

$$3 \times 12 = 36$$

The products 36 and 36 **are** the same.

Therefore $\frac{2}{3} = \frac{12}{18}$

Example C: Compare $\frac{24}{40}$ and $\frac{4}{10}$

$$24 \times 10 = 240$$

$$40 \times 4 = 160$$

The products 240 and 160 **are not** the same.

Therefore $\frac{24}{40} \neq \frac{4}{10}$

Exercise Four

State if each pair is equivalent (=) or not equivalent (\neq). Use whichever method you wish to find the answer.

a) $\frac{5}{6} \text{ — } \frac{30}{60}$

b) $\frac{12}{24} \text{ — } \frac{1}{2}$

c) $\frac{6}{7} \text{ — } \frac{7}{8}$

d) $\frac{2}{3} \text{ — } \frac{12}{18}$

e) $\frac{1}{3} \text{ — } \frac{24}{72}$

f) $\frac{3}{4} \text{ — } \frac{15}{20}$

g) $\frac{12}{15} \text{ — } \frac{6}{7}$

h) $\frac{1}{2} \text{ — } \frac{30}{50}$

i) $\frac{8}{16} \text{ — } \frac{5}{10}$

j) $\frac{12}{14} \text{ — } \frac{6}{7}$

k) $\frac{4}{10} \text{ — } \frac{20}{50}$

l) $\frac{5}{10} \text{ — } \frac{7}{14}$

Answers to Exercise Four

a) \neq b) = c) \neq d) = e) = f) = g) \neq
h) \neq i) = j) = k) = l) =

Rounding Common Fractions to Whole Numbers

When rounding to a whole number, if a fraction is less than $\frac{1}{2}$ do not change the whole number:

Examples:

$$2\frac{2}{5} \approx 2$$

$$\frac{1}{4} \approx 0$$

$$23\frac{1}{3} \approx 23$$

$$5\frac{3}{8} \approx 5$$

If the fraction is $\frac{1}{2}$ or more, consider the fraction as **another one**, which must be added to the whole number:

Examples:

$$2\frac{1}{2} \approx 3$$

$$6\frac{7}{8} \approx 7$$

$$15\frac{4}{5} \approx 16$$

$$\frac{3}{4} \approx 1$$

If you are not sure if a fraction is more or less than $\frac{1}{2}$, you can compare it to $\frac{1}{2}$ by making equivalent fractions with a common denominator.

Reminder: greater > smaller

Example A: Round $2\frac{2}{3}$ to a whole number.

$$\text{Is } \frac{2}{3} > \frac{1}{2} ?$$

$$\frac{2}{3} = \frac{4}{6}$$

$$\frac{1}{2} = \frac{3}{6}$$

$$\text{Yes, } \frac{2}{3} > \frac{1}{2}, \text{ so } 2\frac{2}{3} \approx 3$$

Example B: Round $2\frac{4}{7}$ to a whole number.

$$\text{Is } \frac{4}{7} > \text{ or } < \frac{1}{2} ?$$

$$\frac{4}{7} = \frac{8}{14}$$

$$\frac{1}{2} = \frac{7}{14}$$

$$\frac{4}{7} > \frac{1}{2}, \text{ so } 2\frac{4}{7} \approx 3$$

Exercise Five

Round to the nearest whole number.

a) $\frac{4}{5} \approx \underline{1}$

b) $2\frac{1}{3} \approx \underline{2}$

c) $18\frac{1}{2} \approx \underline{\quad}$

d) $3\frac{7}{8} \approx \underline{\quad}$

e) $9\frac{9}{10} \approx \underline{\quad}$

f) $\frac{1}{8} \approx \underline{\quad}$

g) $4\frac{1}{6} \approx \underline{\quad}$

h) $12\frac{7}{9} \approx \underline{\quad}$

i) $6\frac{3}{5} \approx \underline{\quad}$

j) $20\frac{3}{7} \approx \underline{\quad}$

k) $\frac{13}{15} \approx \underline{\quad}$

l) $99\frac{2}{3} \approx \underline{\quad}$

Answers to Exercise Five

c) 19

d) 4

e) 10

f) 0

g) 4

h) 13

i) 7

j) 20

k) 1

l) 100

Topic A Self-Test

Mark /25 Aim 20/25

A. Define

3 marks

a) equivalent _____

b) prime number _____

c) greatest common factor (GCF) _____

B. Complete the chart:

5 marks

| | Factors | Common Factors | Greatest Common Factor |
|-------------|---------|----------------|------------------------|
| a) 12 18 | | | |
| b) 15 30 | | | |
| c) 7 28 | | | |
| d) 6 16 | | | |
| e) 18 27 | | | |

C. Express in lowest terms.**6 marks**

a) $\frac{4}{8} =$ _____

b) $\frac{3}{9} =$ _____

c) $\frac{12}{16} =$ _____

d) $\frac{10}{25} =$ _____

e) $\frac{14}{16} =$ _____

f) $\frac{8}{12} =$ _____

D. State if each pair of fractions is equivalent (=) or not equivalent (\neq).**6 marks**

a) $\frac{5}{9}$ _____ $\frac{15}{27}$

b) $\frac{6}{36}$ _____ $\frac{4}{18}$

c) $\frac{3}{7}$ _____ $\frac{15}{35}$

d) $\frac{4}{15}$ _____ $\frac{20}{55}$

e) $\frac{3}{7}$ _____ $\frac{6}{15}$

f) $\frac{2}{3}$ _____ $\frac{9}{15}$

E. Round to the nearest whole number.**5 marks**

a) $4\frac{5}{8} \approx$ _____

b) $19\frac{4}{10} \approx$ _____

c) $\frac{1}{2} \approx$ _____

d) $6\frac{3}{4} \approx$ _____

e) $\frac{1}{3} \approx$ _____

Answers to Topic B Self-Test

A.

Check your definitions in the glossary.

B.

| | Factors | Common Factors | Greatest Common Factor |
|-------------|--|-----------------------|-------------------------------|
| a) 12 18 | ... of 12 are 1, 2, 3, 4, 6, 12 ... of 18 are 1, 2, 3, 6, 9, 18 | 2, 3, 6 | 6 |
| b) 15 30 | ... of 15 are 1, 3, 5, 15 ... of 30 are 1, 2, 3, 5, 6, 10, 15, 30 | 3, 5, 15 | 15 |
| c) 7 28 | ... of 7 are 1, 7 ... of 28 are 1, 2, 4, 7, 14, 28 | 7 | 7 |
| d) 6 16 | ... of 6 are 1, 2, 3, 6 ... of 16 are 1, 2, 4, 8, 16 | 2 | 2 |
| e) 18 27 | ... of 18 are 1, 2, 3, 6, 9, 18 ... of 27 are 1, 3, 9, 27 | 3, 9 | 9 |

C.

- a) $\frac{1}{2}$ b) $\frac{1}{3}$ c) $\frac{3}{4}$ d) $\frac{2}{5}$ e) $\frac{7}{8}$ f) $\frac{2}{3}$

D.

- a) = b) \neq c) = d) \neq e) \neq f) \neq

E.

- a) 5 b) 19 c) 1 d) 7 e) 0

Unit 2 Review

1. Find all the factors for each number, some of the numbers are prime numbers, write 'prime' next to it.

a) 4 _____

b) 10 _____

c) 21 _____

d) 6 _____

e) 2 _____

f) 16 _____

g) 20 _____

h) 8 _____

i) 25 _____

j) 9 _____

k) 3 _____

l) 18 _____

2. Find the factors, common factors and the Greatest Common Factor (GCF).

| | Fraction | Factors | Common Factors | G.C.F. |
|----|-----------------|----------------|-----------------------|---------------|
| a) | $\frac{2}{8}$ | | | |
| b) | $\frac{8}{16}$ | | | |
| c) | $\frac{24}{32}$ | | | |
| d) | $\frac{9}{12}$ | | | |
| e) | $\frac{5}{15}$ | | | |
| f) | $\frac{25}{30}$ | | | |
| g) | $\frac{4}{12}$ | | | |
| h) | $\frac{3}{9}$ | | | |
| i) | $\frac{4}{32}$ | | | |
| j) | $\frac{3}{15}$ | | | |
| k) | $\frac{2}{10}$ | | | |
| l) | $\frac{6}{15}$ | | | |

3. Express each fraction in lowest terms. Remember: be sure to write the GCF you are dividing with.

a) $\frac{6}{9} = \underline{\hspace{2cm}}$

g) $\frac{15}{30} = \underline{\hspace{2cm}}$

b) $\frac{6}{18} = \underline{\hspace{2cm}}$

h) $\frac{4}{24} = \underline{\hspace{2cm}}$

c) $\frac{12}{28} = \underline{\hspace{2cm}}$

i) $\frac{10}{18} = \underline{\hspace{2cm}}$

d) $\frac{2}{16} = \underline{\hspace{2cm}}$

j) $\frac{2}{32} = \underline{\hspace{2cm}}$

e) $\frac{6}{20} = \underline{\hspace{2cm}}$

k) $\frac{3}{18} = \underline{\hspace{2cm}}$

f) $\frac{10}{30} = \underline{\hspace{2cm}}$

l) $\frac{6}{24} = \underline{\hspace{2cm}}$

4. Circle the fractions that are in lowest terms.

a) $\frac{1}{2}$

b) $\frac{3}{6}$

c) $\frac{4}{5}$

d) $\frac{3}{9}$

e) $\frac{4}{8}$

f) $\frac{5}{10}$

g) $\frac{1}{7}$

h) $\frac{3}{12}$

i) $\frac{2}{5}$

j) $\frac{2}{4}$

5. Find all the fractions that are not already in lowest terms and reduce them. Write 'lowest terms' next to those already reduced.

a) $\frac{4}{8} =$ _____

b) $\frac{1}{3} =$ _____

c) $\frac{2}{5} =$ _____

d) $\frac{3}{9} =$ _____

e) $\frac{8}{12} =$ _____

f) $\frac{14}{16} =$ _____

g) $\frac{1}{9} =$ _____

h) $\frac{2}{10} =$ _____

i) $\frac{15}{35} =$ _____

j) $\frac{3}{7} =$ _____

k) $\frac{42}{80} =$ _____

l) $\frac{15}{27} =$ _____

m) $\frac{6}{36} =$ _____

n) $\frac{9}{42} =$ _____

o) $\frac{9}{15} =$ _____

6. State if each pair of fractions is equivalent (=) or not equivalent (\neq).

a) $\frac{4}{5}$ _____ $\frac{7}{8}$

b) $\frac{1}{3}$ _____ $\frac{22}{44}$

c) $\frac{10}{12}$ _____ $\frac{5}{6}$

d) $\frac{3}{4}$ _____ $\frac{15}{20}$

e) $\frac{5}{15}$ _____ $\frac{1}{3}$

f) $\frac{4}{16}$ _____ $\frac{2}{8}$

g) $\frac{6}{7}$ _____ $\frac{36}{41}$

h) $\frac{4}{9}$ _____ $\frac{9}{18}$

i) $\frac{3}{5}$ _____ $\frac{15}{25}$

7. Round to the nearest whole number.

a) $1\frac{1}{4} =$ _____

b) $3\frac{1}{3} =$ _____

c) $4\frac{3}{4} =$ _____

d) $1\frac{1}{2} =$ _____

e) $6\frac{4}{5} =$ _____

f) $12\frac{7}{8} =$ _____

g) $3\frac{1}{4} =$ _____

h) $17\frac{1}{17} =$ _____

i) $12\frac{8}{9} =$ _____

j) $2\frac{1}{4} =$ _____

Answers to Review

1.

- | | |
|-----------------------|-------------------------|
| a) 1, 2, 4 | h) 1, 2, 4, 8 |
| b) 1, 2, 5, 10 | i) 1, 5, 25 |
| c) 1, 3, 7, 21 | j) 1, 3, 9 |
| d) 1, 2, 3, 6 | k) 1, 3 prime |
| e) 1, 2 prime | l) 1, 2, 3, 4, 6, 9, 18 |
| f) 1, 2, 4, 8, 16 | |
| g) 1, 2, 4, 5, 10, 20 | |

2.

| | Fraction | Factors | Common Factors | G.C.F. |
|-----------|-----------------|---|-----------------------|---------------|
| a) | $\frac{2}{8}$ | 1, 2 1, 2, 4, 8 | 2, 4 | 4 |
| b) | $\frac{8}{16}$ | 1, 2, 4, 8 1, 2, 4, 8, 16 | 2, 4, 8 | 8 |
| c) | $\frac{24}{32}$ | 1, 2, 3, 4, 6, 8, 12, 24 1, 2, 4, 8, 16, 32 | 2, 4, 8 | 8 |
| d) | $\frac{9}{12}$ | 1, 3, 9 1, 2, 3, 4, 6, 12 | 3 | 3 |
| e) | $\frac{5}{15}$ | 1, 5 1, 3, 5, 15 | 5 | 5 |
| f) | $\frac{25}{30}$ | 1, 5, 25 1, 2, 3, 5, 6, 10, 15, 30 | 5 | 5 |
| g) | $\frac{4}{12}$ | 1, 2, 4 1, 2, 3, 4, 6, 12 | 2, 4 | 4 |
| h) | $\frac{3}{9}$ | 1, 3 1, 3, 9 | 3 | 3 |
| i) | $\frac{4}{32}$ | 1, 2, 4 1, 2, 4, 8, 16, 32 | 2, 4 | 4 |
| j) | $\frac{3}{15}$ | 1, 3 1, 3, 5, 15 | 3 | 3 |
| k) | $\frac{2}{10}$ | 1, 2 1, 2, 5, 10 | 2 | 2 |
| l) | $\frac{6}{15}$ | 1, 2, 3, 6 1, 3, 5, 15 | 3 | 3 |

3.

- a) $\frac{2}{3}$ b) $\frac{1}{3}$ c) $\frac{3}{7}$ d) $\frac{1}{8}$ e) $\frac{3}{10}$ f) $\frac{1}{3}$
g) $\frac{1}{2}$ h) $\frac{1}{6}$ i) $\frac{5}{9}$ j) $\frac{1}{16}$ k) $\frac{1}{6}$ l) $\frac{1}{4}$

4.

- a) $\frac{1}{2}$ c) $\frac{4}{5}$ g) $\frac{1}{7}$ i) $\frac{2}{5}$

5.

- a) $\frac{1}{2}$ b) lowest terms c) lowest terms d) $\frac{1}{3}$ e) $\frac{2}{3}$ f) $\frac{7}{8}$
g) lowest terms h) $\frac{1}{5}$ i) $\frac{5}{7}$ j) lowest terms k) $\frac{21}{40}$
l) $\frac{5}{9}$ m) $\frac{1}{6}$ n) $\frac{3}{14}$ o) $\frac{3}{5}$

6.

- a) \neq b) \neq c) = d) = e) = f) = g) \neq h) \neq i) =

7.

- a) 1 b) 3 c) 5 d) 2 e) 7 f) 13 g) 3 h) 17 i) 13 j) 2

It is now test time!

Please get the practice test
from your instructor.

Once you are ready, you can get
the unit 2 test from your instructor.

Good luck!

Unit Three

Multiplying & Dividing Fractions

Topic A: Multiplying Fractions

Practice Example A: What is $\frac{1}{4}$ of 4? Here are four equal shapes:

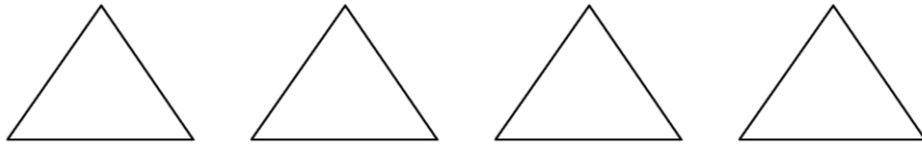

Shade in $\frac{1}{4}$ of the shapes.

You should have one shape shaded.

You have just done this multiplication question: $\frac{1}{4} \times 4 = 1$ or $\frac{1}{4}$ of 4 = 1

Practice Example B: What is $\frac{2}{5}$ of 5? Draw 5 equal shapes.



Shade in $\frac{2}{5}$ of the shapes.

You should have shaded in two shapes. $\frac{2}{5} \times 5 = 2$ or $\frac{2}{5}$ of 5 = 2

Practice Example C: What is $\frac{1}{2}$ of 10? Here are 10 equal shapes:

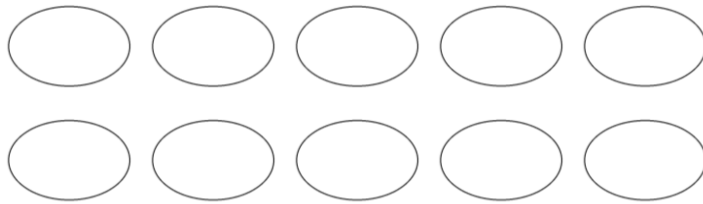

Shade in $\frac{1}{2}$ of the shapes.

Did you shade 5? $\frac{1}{2} \times 10 = 5$ or $\frac{1}{2}$ of 10 = 5

Practice Example D: What is $\frac{1}{4}$ of 8?



Shade $\frac{1}{4}$ of the shapes.

- First, divide the 8 shapes into 4 equal groups.

- Now shade 1 group.

$$\frac{1}{4} \times 8 = 2 \text{ or } \frac{1}{4} \text{ of } 8 = 2$$

Practice Example E: What is $\frac{2}{3}$ of 6?



Shade $\frac{2}{3}$ of the shapes.

- First, divide the 6 shapes into 3 equal groups.

- Now shade 2 of the groups.

$$\frac{2}{3} \times 6 = 4$$

These examples calculate **a fraction of a whole number**. Some everyday examples, with the answers, are listed:

A. I burned $\frac{1}{2}$ of the hamburger patties. There were 8 patties. How many patties were burned?

$$\frac{1}{2} \text{ of } 8 \text{ patties} = \frac{1}{2} \times 8 = 4 \text{ burned patties}$$

B. Mary only finished $\frac{3}{4}$ of the test. The test had 20 questions. How many questions did Mary do?

$$\frac{3}{4} \text{ of test} = \frac{3}{4} \text{ of } 20 \text{ questions} = \frac{3}{4} \times 20 = 15 \text{ questions}$$

C. $\frac{1}{5}$ of the employees have been laid off. There are 50 employees. How many have been laid off?

$$\frac{1}{5} \text{ of } 50 \text{ employees} = \frac{1}{5} \times 50 = 10 \text{ employees laid off}$$

D. We spend $\frac{1}{4}$ of our monthly take home pay on rent. Our take home pay is \$1600. How much is the rent?

$$\frac{1}{4} \text{ of pay} = \frac{1}{4} \text{ of } \$1600 = \frac{1}{4} \times \$1600 = \$400 \text{ on rent}$$

Exercise One

Write the multiplication equation you would use to find the fraction of the whole number. You do not have to calculate the answers.

a) More than $\frac{1}{3}$ of the students are single parents. There are 27 students. How many students are single parents?

b) We have ten houses on our street. $\frac{2}{5}$ of the houses have cedar shake roofs. How many houses have cedar shake roofs?

c) The guinea hen hatched 16 chicks. The ravens snatched $\frac{3}{8}$ of the chicks. How many chicks did the ravens take?

Answers to Exercise One

$$a) \frac{1}{3} \times 27 = 9$$

$$b) \frac{2}{5} \times 10 = 4$$

$$c) \frac{3}{8} \times 16 = 6$$

Now let's look at multiplying a fraction by a whole number.

$$4 \times \frac{1}{2} = \square$$

$$3 \times \frac{4}{5} = \square$$

$$2 \times \frac{1}{4} = \square$$

The order of writing the multiplication equation will not change the product, but it does change how we understand what the numbers mean. Again, look at the examples:

Example A:

$4 \times \frac{1}{2}$ means you have four halves.

Imagine tomatoes cut in half and you have 4 halves.

How many tomatoes would you have altogether?

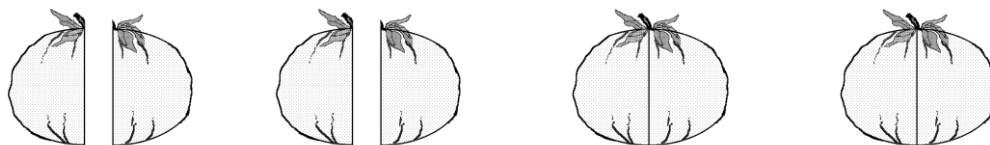

4 halves = 2 tomatoes

$$4 \times \frac{1}{2} = 2$$

Example B:

$3 \times \frac{1}{4}$ means that you have $\frac{1}{4}$ of something three times. Imagine that you spent $\frac{1}{4}$ of an hour exercising in the morning, $\frac{1}{4}$ of an hour exercising after lunch, and $\frac{1}{4}$ of an hour exercising in the evening.

How long did you exercise?

$$3 \times \frac{1}{4} \text{ hour} = \frac{3}{4} \text{ hour} = \text{three quarters of an hour}$$

Here are some everyday examples of multiplying a fraction by a whole number:

C. There are six boxes of cereal open in the cupboard and each one is $\frac{1}{3}$ full.

It is the same as having ___ full boxes of cereal.

$$6 \times \frac{1}{3} \text{ box of cereal} = \frac{6}{3} = 2 \text{ boxes of cereal.}$$

D. We have three packs of ground beef that are $\frac{1}{2}$ full. How much meat is there altogether?

$$3 \times \frac{1}{2} \text{ pack of meat} = \frac{3}{2} = 1\frac{1}{2} \text{ packs of meat.}$$

E. How much gas do we have for the motorboat? There are 4 jerry cans (cans for carrying gas), each about $\frac{1}{4}$ full.

$$4 \times \frac{1}{4} \text{ can of gas} = \frac{4}{4} = 1 \text{ can of gas}$$

Exercise Two

Write the multiplication equation you would use to multiply a fraction by a whole number. You **do not** have to calculate the answer.

a) You say I should buy more shampoo but this bathroom has five bottles of the stuff lying around! Each bottle is about $\frac{1}{8}$ full. How much shampoo is there altogether?

b) When we double a recipe we multiply each ingredient by 2. Double a recipe that uses $\frac{1}{4}$ teaspoon of nutmeg. How much nutmeg is needed?

Answers to Exercise Two

a) $5 \times \frac{1}{8} = \frac{5}{8}$

b) $\frac{1}{4} \times 2 = \frac{1}{2}$

Multiplying a Whole Number and a Proper Fraction

Any whole number can be written with a denominator of 1. (This does not change the value of the whole number because a number divided by one is still the whole number in the end.)

$$1 = \frac{1}{1}$$

$$2 = \frac{2}{1}$$

$$3 = \frac{3}{1}$$

$$4 = \frac{4}{1}$$

$$100 = \frac{100}{1} \quad \text{and so on.}$$

To multiply a whole number and a fraction, do this:

Step 1 - Write the whole number as a fraction with a denominator of 1.

Step 2 - Multiply the numerator by the numerator.

Step 3 - Multiply the denominator by the denominator.

Step 4 - Simplify the product.

Example A: $\frac{4}{5} \times 6 = \square$

Step 1 Write the whole number with a denominator of 1.

$$\frac{4}{5} \times \frac{6}{1} = \square$$

Step 2 Multiply the numerators.

$$\frac{4}{5} \times \frac{6}{1} = \frac{24}{5}$$

Step 3 Multiply the denominators.

$$\frac{4}{5} \times \frac{6}{1} = \frac{24}{5}$$

Step 4 Simplify the product.

$$\text{Since } \begin{array}{r} 4 \\ 5 \overline{)24} \\ \underline{-20} \\ 4 \end{array} \quad \frac{24}{5} = 4 \frac{4}{5} \quad \text{Then } \frac{4}{5} \times 6 = 4 \frac{4}{5}$$

Example B: $\frac{1}{2} \times 3 = \square$

Step 1 $\frac{1}{2} \times \frac{3}{1} = \square$

Step 2 & 3 $\frac{1}{2} \times \frac{3}{1} = \frac{3}{2}$

Step 4

$$\text{Since } \begin{array}{r} 1 \\ 2 \overline{)3} \\ \underline{-2} \\ 1 \end{array} \quad \frac{3}{2} = 1 \frac{1}{2} \quad \text{Then } \frac{1}{2} \times 3 = 1 \frac{1}{2}$$

Example C: $\frac{2}{3} \times 4 = \square$

$$\frac{2}{3} \times \frac{4}{1} = \frac{8}{3} = 2 \frac{2}{3} \quad \begin{array}{r} 2 \\ 3 \overline{)8} \\ \underline{-6} \\ 2 \end{array}$$

Example D: $7 \times \frac{3}{4} = \square$

$$\frac{7}{1} \times \frac{3}{4} = \frac{21}{4} = 5 \frac{1}{4}$$

$$\begin{array}{r} 5 \\ 4 \overline{)21} \\ \underline{-20} \\ 1 \end{array}$$

Exercise Three

Multiply these fractions. Write your answers in lowest terms.

a) $\frac{3}{5} \times 10 =$

$$\frac{3}{5} \times \frac{10}{1} = \frac{30}{5} = 6$$

$$\begin{array}{r} 6 \\ 5 \overline{)30} \\ \underline{-30} \\ 0 \end{array}$$

b) $\frac{1}{10} \times 8 =$

$$\frac{1}{10} \times \frac{8}{1} = \frac{8}{10} = \frac{8 \div 2}{10 \div 2} = \frac{4}{5}$$

c) $\frac{2}{3} \times 9 =$

d) $4 \times \frac{1}{6} =$

e) $1 \times \frac{3}{8} =$

f) $\frac{1}{2} \times 5 =$

g) $5 \times \frac{2}{3} =$

h) $4 \times \frac{2}{5} =$

i) $\frac{1}{2} \times 8 =$

j) $\frac{3}{8} \times 8 =$

k) $6 \times \frac{1}{5} =$

l) $6 \times \frac{3}{4} =$

m) $\frac{3}{2} \times 12 =$

n) $7 \times \frac{2}{3} =$

o) $\frac{3}{8}$ of 4 =

p) $\frac{5}{6}$ of 3 =

q) $\frac{7}{8}$ of 3

r) $\frac{5}{7}$ of 5

Answers to Exercise Three

c) 6

d) $\frac{2}{3}$

e) $\frac{3}{8}$

f) $2\frac{1}{2}$

g) $3\frac{1}{3}$

h) $1\frac{3}{5}$

i) 4

j) 3

k) $1\frac{1}{5}$

l) $4\frac{1}{2}$

m) 18

n) $4\frac{2}{3}$

o) $1\frac{1}{2}$

p) $2\frac{1}{2}$

q) $2\frac{5}{8}$

r) $3\frac{4}{7}$

Multiplying Common Fractions Together

To multiply common fractions, multiply the numerator times the numerator and then the denominator times the denominator and simplify the answer. (Write the answer in lowest terms.)

The method is easy, but let's take a look at what you're doing.

Example A: $\frac{1}{2} \times \frac{1}{2} = \frac{1}{2}$ of $\frac{1}{2} = \square$

Take an apple and cut it in half.

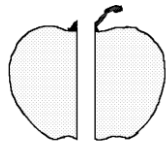

Now cut one of the halves in half. What fraction of the whole apple do you get?



You get $\frac{1}{4}$ of the apple.

$$\frac{1}{2} \times \frac{1}{2} = \frac{1}{4}$$

Example B: $\frac{1}{3} \times \frac{3}{4} = \frac{1}{3}$ of $\frac{3}{4} = \square$

You borrowed $\frac{3}{4}$ of a bag of cement from your neighbour. You used $\frac{1}{3}$ of the cement and gave the bag back to him. How much of your neighbour's bag of cement did you use?

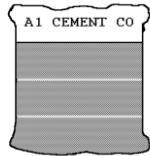

$\frac{3}{4}$ of a bag

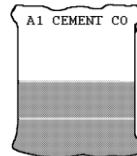

$\frac{2}{4}$ of a bag left

use $\frac{1}{3}$ of this

$$\frac{1}{3} \text{ of } \frac{3}{4} = \frac{3}{12} = \frac{1}{4} \text{ of the bag used}$$

used $\frac{1}{4}$ of a bag

Example C: $\frac{1}{2}$ of $\frac{2}{3} = \frac{1}{2} \times \frac{2}{3} = \square$

You are making a marinade to tenderize that cheap steak you bought. It calls for $\frac{2}{3}$ cup of beer. You only need $\frac{1}{2}$ of the amount the recipe makes and it would be a shame to waste the beer. How much beer is needed?

$\frac{1}{2}$ of $\frac{2}{3}$ cup =

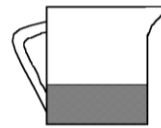
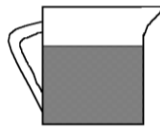

$\frac{1}{3}$ cup

$$\frac{1}{2} \text{ of } \frac{2}{3} \text{ cup of beer} = \frac{1}{2} \times \frac{2}{3} = \frac{2}{6} = \frac{2}{6} \frac{\div 2}{\div 2} = \frac{1}{3} \text{ cup of beer}$$

Exercise Four

Multiply these fractions. Write the answers in lowest terms.

a) $\frac{1}{2} \times \frac{1}{2} = \frac{1}{4}$

b) $\frac{1}{2} \times \frac{3}{2} = \underline{\hspace{2cm}}$

c) $\frac{1}{2} \times \frac{4}{2} = \underline{\hspace{2cm}}$

d) $\frac{1}{5} \times \frac{2}{3} = \underline{\hspace{2cm}}$

e) $\frac{3}{5} \times \frac{2}{4} = \underline{\hspace{2cm}}$

f) $\frac{2}{3} \times \frac{2}{3} = \underline{\hspace{2cm}}$

g) $\frac{2}{5} \times \frac{3}{5} = \underline{\hspace{2cm}}$

h) $\frac{5}{7} \times \frac{3}{4} = \underline{\hspace{2cm}}$

i) $\frac{5}{6} \times \frac{1}{4} = \underline{\hspace{2cm}}$

j) $\frac{3}{4} \times \frac{2}{3} = \underline{\hspace{2cm}}$

k) $\frac{5}{10} \times \frac{1}{4} = \underline{\hspace{2cm}}$

l) $\frac{1}{8} \times \frac{2}{3} = \underline{\hspace{2cm}}$

m) $\frac{1}{4} \times \frac{1}{8} = \underline{\hspace{2cm}}$

n) $\frac{7}{9} \times \frac{1}{7} = \underline{\hspace{2cm}}$

o) $\frac{8}{10} \times \frac{2}{3} = \underline{\hspace{2cm}}$

p) $\frac{1}{9} \times \frac{2}{3} = \underline{\hspace{2cm}}$

Answers to Exercise Four

b) $\frac{3}{4}$

c) 2

d) $\frac{12}{15}$

e) $\frac{3}{10}$

f) $\frac{4}{9}$

g) $\frac{6}{25}$

h) $\frac{15}{28}$

i) $\frac{5}{24}$

j) $\frac{1}{2}$

k) $\frac{1}{8}$

l) $\frac{1}{12}$

m) $\frac{1}{32}$

n) $\frac{1}{9}$

o) $\frac{8}{15}$

p) $\frac{2}{27}$

Simplify Before Multiplying

Review Factors and Expressing Fractions in Lower Terms in Topic B. Multiplication of common fractions can be made much easier if you simplify before you multiply. In a multiplication question any numerator and any denominator may be divided by a common factor. This is sometimes called cancelling.

Step 1 Look to see if any numerator and any denominator have common factors.

Choose the greatest common factor.

Step 2 Divide that numerator and that denominator by the greatest common factor (G.C.F.). Be sure to cross out the old numerals and put in the lower terms.

Step 3 Multiply the numerators (Be sure to use the lower term!) and then the denominators.

Step 4 Simplify.

Example A: $\frac{3}{4} \times \frac{1}{6} = \square$

Step 1 Numerator 3 and denominator 6 have a common factor of 3.

Step 2 $\frac{\cancel{3}^1}{4} \times \frac{1}{\cancel{6}_2}$ $3 \div 3 = 1$ and $6 \div 3 = 2$

Step 3 $\frac{\cancel{3}^1}{4} \times \frac{1}{\cancel{6}_2} = \frac{1}{8}$

Step 4 The answer is already in lowest terms.

Example B: $\frac{3}{4} \times \frac{8}{9} = \square$

Step 1 Numerator 3 and denominator 9 have a common factor of 3, AND numerator 8 and denominator 4 have common factors of 2 and 4. The G.C.F. is 4.

Step 2 $\frac{\cancel{3}^1}{\cancel{4}_1} \times \frac{\cancel{8}^2}{\cancel{9}_3}$ $3 \div 3 = 1$, $9 \div 3 = 3$, $8 \div 4 = 2$, and $4 \div 4 = 1$

Step 3 $\frac{\cancel{3}^1}{\cancel{4}_1} \times \frac{\cancel{8}^2}{\cancel{9}_3} = \frac{2}{3}$

Step 4 The answer is already in lowest terms.



It is easier to simplify (or cancel) before you multiply because the numbers are smaller and the factors easier to find. You may make fewer multiplying mistakes, too.

Example C: $\frac{3}{8} \times 12 = \square$

$\frac{3}{8} \times \frac{12}{1}$ (Numerator 12 and denominator 8 have a G.C.F. of 4)

$\frac{3}{\cancel{8}_2} \times \frac{\cancel{12}^3}{1} = \frac{9}{2} = 4\frac{1}{2}$

Exercise Five

Find the products. Simplify before multiplying when possible.

a) $\frac{5}{6} \times \frac{4}{5} = \underline{\hspace{2cm}}$

b) $\frac{3}{5} \times \frac{5}{9} = \underline{\hspace{2cm}}$

$\frac{\cancel{5}^1}{\cancel{6}_3} \times \frac{\cancel{4}^2}{\cancel{5}_1} = \frac{2}{3}$

$\frac{\cancel{3}^1}{\cancel{5}_1} \times \frac{\cancel{5}^1}{\cancel{9}_3} = \frac{1}{3}$

c) $\frac{3}{16} \times \frac{8}{9} = \underline{\hspace{2cm}}$

d) $\frac{7}{9} \times \frac{3}{7} = \underline{\hspace{2cm}}$

e) $\frac{2}{5} \times \frac{5}{8} = \underline{\hspace{2cm}}$

f) $\frac{4}{5} \times \frac{7}{8} = \underline{\hspace{2cm}}$

g) $\frac{4}{21} \times \frac{7}{8} = \underline{\hspace{2cm}}$

h) $\frac{3}{8} \times \frac{4}{9} = \underline{\hspace{2cm}}$

i) $\frac{9}{10} \times \frac{2}{3} = \underline{\hspace{2cm}}$

j) $\frac{3}{10} \times \frac{5}{12} = \underline{\hspace{2cm}}$

$$\text{k) } \frac{2}{5} \times \frac{10}{7} = \underline{\hspace{2cm}}$$

$$\text{l) } \frac{5}{8} \times 16 = \underline{\hspace{2cm}}$$

$$\text{m) } \frac{3}{4} \times \frac{1}{12} = \underline{\hspace{2cm}}$$

$$\text{n) } \frac{7}{8} \times \frac{12}{21} = \underline{\hspace{2cm}}$$

A multiplication question may have more than two fractions to be multiplied, such as

$$\frac{2}{3} \times \frac{9}{10} \times \frac{5}{8} = \square$$

Cancel any numerator with any denominator and then multiply all numerators together and then all denominators together. Study this worked example:

Numerator 2 and denominator 8 have a common factor of 2, numerator 9 and denominator 3 have a common factor of 3, AND numerator 5 and denominator 10 have a common factor of 5.

$$\frac{\cancel{2}^1}{\cancel{3}_1} \times \frac{\cancel{9}^3}{\cancel{10}_2} \times \frac{\cancel{5}^1}{\cancel{8}_4} = \frac{3}{8}$$

$$\text{o) } \frac{8}{9} \times \frac{3}{4} = \underline{\hspace{2cm}}$$

$$\text{p) } \frac{1}{2} \times \frac{2}{5} \times \frac{5}{7} = \underline{\hspace{2cm}}$$

$$\text{q) } \frac{3}{5} \times \frac{2}{3} \times \frac{1}{2} = \underline{\hspace{2cm}}$$

$$\text{r) } 2 \times \frac{3}{4} \times \frac{5}{12} = \underline{\hspace{2cm}}$$

$$\text{s) } \frac{4}{9} \times \frac{3}{5} \times \frac{15}{16} = \underline{\hspace{2cm}}$$

$$\text{t) } \frac{2}{3} \times \frac{3}{4} \times \frac{8}{9} = \underline{\hspace{2cm}}$$

Answers to Exercise Five

c) $\frac{1}{6}$

d) $\frac{1}{3}$

e) $\frac{1}{4}$

f) $\frac{7}{10}$

g) $\frac{1}{6}$

h) $\frac{1}{6}$

i) $\frac{3}{5}$

j) $\frac{1}{8}$

k) $\frac{4}{7}$

l) 10

m) $\frac{1}{16}$

n) $\frac{1}{2}$

o) $\frac{2}{3}$

p) $\frac{1}{7}$

q) $\frac{1}{5}$

r) $\frac{5}{8}$

s) $\frac{1}{4}$

t) $\frac{4}{9}$

Multiplying Mixed Numbers

Review Renaming Mixed Numbers as Improper Fractions in Unit Two. To multiply with a mixed number, follow these steps:

- Step 1** Rename any mixed numbers as improper fractions.
- Step 2** Write any whole number by itself as an improper fraction with a denominator of 1.
- Step 3** Rewrite the question with the new improper fraction(s).
- Step 4** Simplify (cancel).
- Step 5** Multiply the numerator by the numerator.
Multiply the denominator by the denominator.
- Step 6** The answer will often be an improper fraction. Rename improper fractions as mixed numbers and be sure any fraction is in lowest terms.

Example A: $2\frac{3}{4} \times \frac{1}{3} = \square$

Step 1 $2\frac{3}{4} = \frac{11}{4}$

Step 2 No whole numbers by themselves.

Step 3 Question is rewritten as $\frac{11}{4} \times \frac{1}{3} = \square$

Step 4 Simplify - no common factors except 1.

Step 5 $\frac{11}{4} \times \frac{1}{3} = \frac{11}{12}$

Step 6 Already in lowest terms.

Example B: $1\frac{1}{5} \times 2\frac{2}{3} = \square$

Step 1 $1\frac{1}{5} = \frac{6}{5}$ and $2\frac{2}{3} = \frac{8}{3}$

Step 2 No whole numbers by themselves.

Step 3 Question is rewritten as $\frac{6}{5} \times \frac{8}{3} = \square$

Step 4 and 5 $\frac{\cancel{6}^2}{5} \times \frac{8}{\cancel{3}_1} = \frac{16}{5}$ (an improper fraction)

Step 6 $\frac{16}{5} = 3\frac{1}{5}$ $\begin{array}{r} 5 \overline{)16} \\ \underline{15} \\ 1 \end{array}$

$$1\frac{1}{5} \times 2\frac{2}{3} = 3\frac{1}{5}$$

Example C: $4 \times 2\frac{5}{6} = \square$

Step 1 and 2 $4 = \frac{4}{1}$ and $2\frac{5}{6} = \frac{17}{6}$

Step 3 The question is rewritten as $\frac{4}{1} \times \frac{17}{6} = \square$

Step 4, 5, and 6 $4 \times 2\frac{5}{6} = \frac{\cancel{4}^2}{1} \times \frac{17}{\cancel{6}_3} = \frac{34}{3} = 11\frac{1}{3}$

Example D: $\frac{2}{3} \times 12 \times 3\frac{1}{2} = \square$

$$\frac{\cancel{2}^1}{\cancel{3}_1} \times \frac{\cancel{12}^4}{1} \times \frac{7}{\cancel{2}_1} = \frac{28}{1} = 28$$

Remember to only skip steps when you are totally confident in your method.
Writing out the steps will help you to get the answer right more often.

Exercise Six

Find the products.

a) $3\frac{1}{2} \times 6 =$ _____

b) $3 \times 1\frac{1}{5} =$ _____

$\frac{7}{2} \times \frac{6^3}{1} = 21$

$\frac{3}{1} \times \frac{6}{5} = \frac{18}{5} = 3\frac{3}{5}$

c) $\frac{3}{14} \times 2\frac{1}{6} \times 12 =$ _____

d) $9 \times 3\frac{1}{3} =$ _____

e) $3 \times 4\frac{1}{3} =$ _____

f) $2\frac{3}{4} \times 8 =$ _____

g) $1\frac{2}{5} \times 15 =$ _____

h) $1\frac{2}{3} \times 6 =$ _____

i) $3\frac{3}{8} \times 8 =$ _____

j) $7 \times 2\frac{1}{7} \times 1\frac{2}{3} =$ _____

k) $4 \times 2\frac{1}{2} =$ _____

l) $10 \times 3\frac{1}{4} =$ _____

m) $2\frac{1}{4} \times 8 = \underline{\hspace{2cm}}$

n) $6 \times 1\frac{1}{3} \times \frac{1}{2} = \underline{\hspace{2cm}}$

o) $4\frac{1}{3} \times 9 = \underline{\hspace{2cm}}$

p) $\frac{3}{8} \times 1\frac{2}{5} \times 10 = \underline{\hspace{2cm}}$

q) $3 \times 2\frac{2}{3} = \underline{\hspace{2cm}}$

r) $3\frac{3}{4} \times 8 = \underline{\hspace{2cm}}$

s) $7 \times 4\frac{1}{7} = \underline{\hspace{2cm}}$

t) $3\frac{1}{5} \times 10 = \underline{\hspace{2cm}}$

u) $16 \times 3\frac{1}{2} = \underline{\hspace{2cm}}$

v) $5 \times 2\frac{1}{5} \times \frac{1}{4} = \underline{\hspace{2cm}}$

w) $6\frac{1}{3} \times 3 = \underline{\hspace{2cm}}$

x) $8 \times 4\frac{1}{8} = \underline{\hspace{2cm}}$

y) $3 \times 1\frac{1}{3} = \underline{\hspace{2cm}}$

z) $8 \times 3\frac{1}{4} = \underline{\hspace{2cm}}$

Answers to Exercise Six

c) $5\frac{4}{7}$

d) 30

e) 13

f) 22

g) 21

h) 10

i) 27

j) 25

k) 10

l) $32\frac{1}{2}$

m) 18

n) 4

o) 39

p) $5\frac{1}{4}$

q) 8

r) 30

s) 29

t) 32

u) 56

v) $2\frac{3}{4}$

w) 19

x) 33

y) 4

z) 26

Exercise Seven

This is extra practice if you feel you need it.

a) $1\frac{1}{2} \times \frac{2}{3} =$ _____

b) $1\frac{1}{2} \times 2\frac{3}{4} =$ _____

c) $1\frac{1}{4} \times 3\frac{1}{2} =$ _____

d) $2\frac{1}{3} \times \frac{4}{7} =$ _____

e) $\frac{1}{3} \times 5\frac{1}{2} =$ _____

f) $\frac{1}{8} \times 3\frac{3}{4} =$ _____

g) $1\frac{1}{6} \times 1\frac{5}{7} =$ _____

h) $1\frac{2}{3} \times 4\frac{1}{5} =$ _____

i) $\frac{1}{2} \times 2\frac{1}{2} =$ _____

j) $\frac{2}{3} \times 3\frac{3}{4} =$ _____

k) $7\frac{1}{4} \times 3\frac{1}{3} =$ _____

l) $\frac{3}{5} \times 1\frac{1}{4} =$ _____

m) $7\frac{1}{3} \times \frac{3}{8} =$ _____

n) $\frac{5}{7} \times 35 =$ _____

o) $2\frac{1}{4} \times 3\frac{1}{2} =$ _____

p) $4\frac{2}{3} \times 4\frac{1}{2} =$ _____

q) $3\frac{1}{5} \times \frac{5}{6} =$ _____

r) $7\frac{2}{3} \times \frac{3}{8} =$ _____

s) $6 \times \frac{2}{3} =$ _____

t) $3\frac{1}{3} \times 4\frac{1}{4} =$ _____

u) $8 \times \frac{5}{6} =$ _____

v) $8\frac{1}{3} \times \frac{5}{6} =$ _____

w) $4\frac{1}{5}$ of $2\frac{1}{2} =$ _____

x) $3\frac{3}{4}$ of $\frac{4}{5} =$ _____

y) $\frac{3}{4}$ of $6\frac{1}{2}$ = _____

z) $3\frac{1}{2}$ of $4\frac{2}{3}$ = _____

Answers to Exercise Seven

- | | | | | | |
|-------------------|--------------------|-------------------|---------------------|--------------------|--------------------|
| a) 1 | b) $4\frac{1}{8}$ | c) $4\frac{3}{8}$ | d) $1\frac{1}{3}$ | e) $1\frac{5}{6}$ | f) $\frac{15}{32}$ |
| g) 2 | h) 7 | i) $1\frac{1}{4}$ | j) $2\frac{1}{2}$ | k) $24\frac{1}{6}$ | l) $\frac{3}{4}$ |
| m) $2\frac{3}{4}$ | n) 25 | o) $7\frac{7}{8}$ | p) 21 | q) $2\frac{2}{3}$ | r) $2\frac{7}{8}$ |
| s) 4 | t) $14\frac{1}{6}$ | u) $6\frac{2}{3}$ | v) $6\frac{17}{18}$ | w) $10\frac{1}{2}$ | x) 3 |
| y) $4\frac{7}{8}$ | z) $16\frac{1}{3}$ | | | | |

Problems using Multiplication of Common Fractions

The following exercise gives some typical word problems for multiplication of fractions. The type of wording is similar for decimals and common fractions.

Remember this important word:

A fraction **of** some number means to **multiply**

Example: $\frac{2}{3}$ of her money means $\frac{2}{3} \times$ amount of the money

$\frac{1}{4}$ of the children means $\frac{1}{4} \times$ number of children

These techniques may help you through the problem solving steps when you're working with common fractions:

- Look for key words.
- Look for familiar patterns in the wording.
- Round fractions to whole numbers to estimate and to try to make sense of the problem.
- Draw a sketch or diagram of what the problem is describing.

List key words which point to multiplication:

Exercise Eight

a) Maria was angry with her children because they had eaten $\frac{2}{3}$ of the 24 cupcakes she had made to take to a meeting. How many cupcakes did the kids eat?

b) Double this recipe for Awesome Chocolate Chip Cookies

$\frac{2}{3}$ cup margarine _____

$\frac{5}{8}$ cup white sugar _____

2 eggs _____

$1\frac{1}{2}$ cups flour _____

1 teaspoon baking soda _____

$\frac{7}{8}$ cup chocolate chips _____

$\frac{2}{3}$ cup vegetable shortening _____

$\frac{5}{8}$ cup brown sugar _____

$1\frac{3}{4}$ teaspoons vanilla _____

1 cup rolled oats _____

$\frac{1}{4}$ teaspoon salt. _____

Cream margarine and shortening well, blend in sugar. Beat in eggs and vanilla. Add dry ingredients, blending very thoroughly. Add chocolate chips and mix. Drop by spoonful onto cookie sheet; cookies will flatten during cooking. Bake in 350° F. oven for 10 to 12 minutes.

- c) Marni is trying to gradually cut down the amount of coffee she drinks. Right now she allows herself $\frac{3}{4}$ of a cup of coffee at breakfast, $\frac{3}{4}$ cup at morning break time, and $\frac{3}{4}$ cup at lunch and another $\frac{3}{4}$ cup after dinner. How many cups of coffee is she drinking per day right now?
- d) Sam's truck uses $\frac{1}{3}$ of a tank of gas every time he drives to his girlfriend's house. His tank holds 75 litres. How many litres of gas does he use to drive to his girlfriend's place?
- e) If you do math for $1\frac{1}{2}$ hours every day you are at school, how many hours do you spend on math per month if you come to school twenty days in a month?

f) David was complaining that his car insurance was the same price as $\frac{7}{8}$ of the cost of his car! His car cost \$1200. What did he pay for car insurance?

g) Sue's family will eat all of one recipe of her favourite pancakes, and be asking for more, but they will not eat a whole doubled recipe. Help her increase this amazing recipe by $1\frac{1}{2}$ times.

$1\frac{1}{2}$ cups flour _____

$1\frac{1}{2}$ cups plain yogurt _____

$1\frac{1}{2}$ tsp. baking soda _____

$\frac{1}{2}$ cup milk _____

$\frac{3}{4}$ tsp. baking powder _____

zest of one orange _____

1 Tbsp. brown sugar _____

$\frac{1}{2}$ cup of fresh orange juice _____

$\frac{1}{4}$ tsp. salt _____

1 Tbsp. butter or oil for cooking _____

2 eggs _____

Mix dry ingredients first, then mix all the wet ingredients together. Mix all the wet ingredients into the dry. Cook and enjoy.

h) Justine was building a dog shed. She spent $\frac{1}{3}$ of an hour on the project every evening for 8 days in a row. How much time did she spend on the project?

i) A park is $1\frac{3}{4}$ km wide and $3\frac{5}{6}$ km long. What is the area of the park?

j) Kaz painted a solid colour background on 3 signs. Each sign was $10\frac{1}{2}$ cm high and $35\frac{3}{4}$ cm long. How much area did she cover in paint?

Answers to Exercise Eight

a) 16 cupcakes

b) Awesome Chocolate Chip Cookies (Doubled)

$1\frac{1}{3}$ cup margarine

$1\frac{1}{3}$ cup vegetable shortening

$1\frac{1}{4}$ cup white sugar

$1\frac{1}{4}$ cup brown sugar

4 eggs

$3\frac{1}{2}$ teaspoons vanilla

3 cups flour

2 cups rolled oats

2 teaspoons baking soda

$\frac{1}{2}$ teaspoon salt

$1\frac{3}{4}$ cup chocolate chips

c) 3 cups

d) 25 L

e) 30 hours

f) \$1 050.00

g) $2\frac{1}{4}$ cups flour

$2\frac{1}{4}$ cups plain yogurt

$2\frac{1}{4}$ tsp. baking soda

$\frac{3}{4}$ cups milk

$1\frac{1}{8}$ tsp. baking powder

zest of one and a half oranges

$1\frac{1}{2}$ Tbsp. brown sugar

$\frac{3}{4}$ cup of fresh orange juice

$\frac{3}{8}$ tsp. salt

$1\frac{1}{2}$ Tbsp. butter or oil for cooking

3 eggs

h) $10\frac{2}{3}$ hours

i) $26\frac{5}{6}$ km²

j) $1126\frac{1}{8}$ cm²

A. Find the products.**10 marks**

a) $\frac{1}{4} \times \frac{3}{8} =$

b) $\frac{3}{8} \times \frac{5}{6} =$

c) $\frac{7}{9} \times \frac{3}{14} =$

d) $\frac{1}{4} \times 12 =$

e) $5 \times \frac{4}{9} =$

f) $1\frac{1}{4} \times \frac{4}{5} =$

g) $\frac{3}{5}$ of $7\frac{2}{9} =$

h) $6 \times 1\frac{2}{3} =$

i) $1\frac{1}{2} \times 1\frac{3}{5} =$

j) $2\frac{7}{8} \times 1\frac{9}{10} =$

B. Solve the following word problems:

8 Marks

a) Frank is putting on a big party. He needs to multiply his favourite tomato sauce by five to make enough to serve his guests. Five times this recipe for him. **2 Marks**

$1 \frac{1}{2}$ Tbsp Olive Oil

1 onion

$\frac{1}{2}$ tsp salt

2 bay leaves

6 garlic cloves

$\frac{1}{3}$ tsp red chile flakes

$1 \frac{3}{4}$ litres diced tomatoes

$1 \frac{1}{4}$ Tbsp brown sugar

b) Joey practices $\frac{3}{4}$ of an hour for his choir each day. How much time does he spend practicing each week? **2 Marks**

c) A Haida longhouse measures $15\frac{1}{4}$ m by $18\frac{1}{3}$ m. What area of land does it cover? **2 Marks**

d) Find the area of the rectangle. **2 Marks**

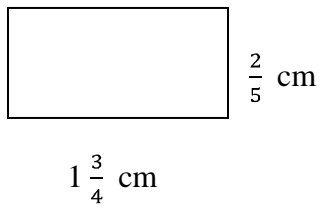

Answers to Topic A Self-Test

A.

a) $\frac{3}{32}$

b) $\frac{5}{16}$

c) $\frac{1}{6}$

d) 3

e) $2\frac{2}{9}$

f) 1

g) $4\frac{1}{3}$

h) 10

i) $2\frac{2}{5}$

j) $5\frac{37}{80}$

B.

a)

 $7\frac{1}{2}$ Tbsp Olive Oil

5 onions

 $2\frac{1}{2}$ tsp salt

10 bay leaves

30 garlic cloves

 $1\frac{2}{3}$ tsp red chile flakes $8\frac{3}{4}$ litres diced tomatoes $6\frac{1}{4}$ Tbsp brown sugar

b) $5\frac{1}{4}$ hours

c) $279\frac{7}{12}$ m² in area

d) $\frac{7}{10}$

Topic B: Dividing Common Fractions

Think over what you know about dividing:

- When we divide, we take the total amount and separate (divide it) into equal parts or groups.
- Remember:

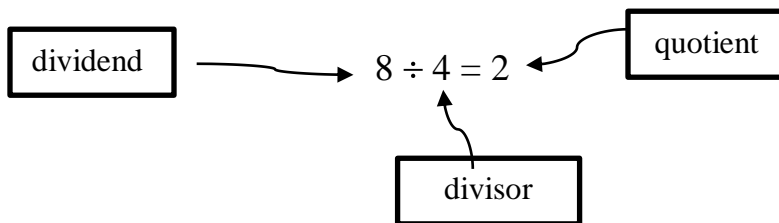

Example A: $8 \div 4 = \square$

The total amount is 8.

The divisor is 4. How many groups of 4 are in 8? Yes, 2.

$$8 \div 4 = 2$$

Example B: $3 \div \frac{1}{2} = \square$

The total amount is 3.

The divisor is $\frac{1}{2}$. How many $\frac{1}{2}$'s are in 3?

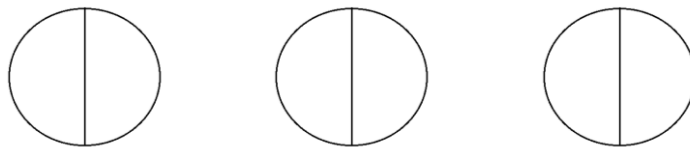

There are 6 halves.

$$3 \div \frac{1}{2} = 6$$

Example C: $2 \div \frac{2}{3} = \square$

The total amount is 2.

The divisor is $\frac{2}{3}$. How many $\frac{2}{3}$'s are in 2?

Use different colours to shade in each group of two that you can find.

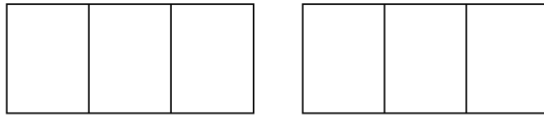

$$2 \div \frac{2}{3} = 3$$

Example D: $1 \div \frac{1}{4} = \square$

Total amount is 1. Divisor is $\frac{1}{4}$.

How many $\frac{1}{4}$'s in 1?

Draw a shape. Divide it into quarters. How many $\frac{1}{4}$'s are there?

There are 4 quarters.

$$1 \div \frac{1}{4} = 4$$

Example E: $3 \div \frac{3}{8} = \square$

How many $\frac{3}{8}$'s in 3.

Use different colours to shade in each group of 3 that you can find.

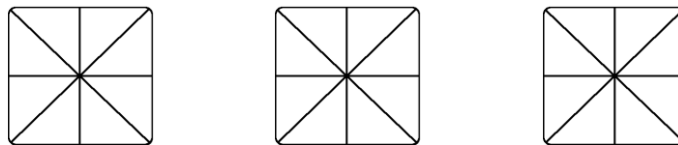

Did you find 8 groups of $\frac{3}{8}$?

$$3 \div \frac{3}{8} = 8$$

Division of fractions by a fraction is difficult to picture, probably because it is not often used in everyday life. Here are some everyday examples for you to think about.

A. You have half a dollar. Someone asks you to change it for quarters. How many quarters are there in half a dollar?

$$\frac{1}{2} \div \frac{1}{4} = 2$$

2 quarters in one half a dollar

B. It takes $\frac{1}{4}$ hour to solve a math problem. How many problems can you solve in $\frac{3}{4}$ of an hour?

$$\frac{3}{4} \div \frac{1}{4} = 3$$

3 problems in $\frac{3}{4}$ of an hour.

Reciprocals

Dividing by a number is the same as multiplying by its reciprocal. We use reciprocals when we divide fractions. Two numbers are reciprocals if they have a product of 1.

To find the reciprocal of a fraction, turn the fraction upside down (flip it over). This is called "inverting the fraction". Some people remember this by thinking of reciprocals as "refliprocals"!

| Fraction | Reciprocal |
|---------------|--|
| $\frac{1}{2}$ | $\frac{2}{1}$ ($\frac{1}{2} \times \frac{2}{1} = \frac{1}{1} = 1$) |
| $\frac{3}{4}$ | $\frac{4}{3}$ ($\frac{3}{4} \times \frac{4}{3} = \frac{12}{12} = 1$) |
| $\frac{7}{8}$ | $\frac{8}{7}$ |
| $\frac{2}{3}$ | $\frac{3}{2}$ |
| $\frac{1}{4}$ | $\frac{4}{1}$ |

To find the reciprocal of a whole number:

- Rename the whole number as a fraction with a denominator of 1.
- Invert the fraction
- Check the reciprocal by multiplying the fraction by the reciprocal.
The product will be one.

| Whole Number | Fraction | Reciprocal | Check |
|--------------|----------------|----------------|--|
| 3 = | $\frac{3}{1}$ | $\frac{1}{3}$ | $\frac{3^1}{1} \times \frac{1}{3_1} = 1$ |
| 6 = | $\frac{6}{1}$ | $\frac{1}{6}$ | $\frac{6^1}{1} \times \frac{1}{6_1} = 1$ |
| 10 = | $\frac{10}{1}$ | $\frac{1}{10}$ | $\frac{10^1}{1} \times \frac{1}{10_1} = 1$ |

To find the reciprocal of a mixed number

- Rename the mixed number as an improper fraction.
- Invert the fraction.

| Mixed Number | Fraction | Reciprocal | Check |
|------------------|----------------|----------------|--|
| $1\frac{1}{2} =$ | $\frac{3}{2}$ | $\frac{2}{3}$ | $\frac{3}{2} \times \frac{2}{3} = \frac{6}{6} = 1$ |
| $2\frac{1}{3} =$ | $\frac{7}{3}$ | $\frac{3}{7}$ | $\frac{7^1}{3_1} \times \frac{3^1}{7_1} = \frac{1}{1} = 1$ |
| $4\frac{3}{8} =$ | $\frac{35}{8}$ | $\frac{8}{35}$ | $\frac{35^1}{8_1} \times \frac{8^1}{35_1} = 1$ |

Exercise One

Write the reciprocal of these numbers.

| | Number | Reciprocal | | Number | Reciprocal |
|----|------------------------------|---------------|----|-----------------|------------|
| a) | $\frac{2}{5}$ | $\frac{5}{2}$ | b) | $\frac{3}{4}$ | |
| c) | $\frac{5}{8}$ | | d) | $\frac{1}{10}$ | |
| e) | $\frac{1}{2}$ | | f) | $\frac{3}{7}$ | |
| g) | $5 = \frac{5}{1}$ | $\frac{1}{5}$ | h) | 7 | |
| i) | 9 | | j) | 11 | |
| k) | 2 | | l) | 8 | |
| m) | $2\frac{1}{2} = \frac{5}{2}$ | $\frac{2}{5}$ | n) | $3\frac{2}{3}$ | |
| o) | $1\frac{1}{4}$ | | p) | $6\frac{2}{5}$ | |
| q) | $8\frac{1}{3}$ | | r) | $3\frac{7}{10}$ | |

Answers to Exercise One

| | | | | | |
|-------------------|-------------------|--------------------|------------------|-------------------|------------------|
| b) $\frac{4}{3}$ | c) $\frac{8}{5}$ | d) 10 | e) 2 | f) $\frac{7}{3}$ | h) $\frac{1}{7}$ |
| i) $\frac{1}{9}$ | j) $\frac{1}{11}$ | k) $\frac{1}{2}$ | l) $\frac{1}{8}$ | n) $\frac{3}{11}$ | o) $\frac{4}{5}$ |
| p) $\frac{5}{32}$ | q) $\frac{3}{25}$ | r) $\frac{10}{37}$ | | | |

Multiplying by the Reciprocal

To divide fractions, multiply by the reciprocal of the divisor.

Step 1 Rewrite the division question.

- rename all mixed numbers as improper fractions
- give any whole numbers a denominator of 1

Step 2 Change the \div sign to a \times sign.

- Invert (turn upside down) the divisor to make the reciprocal.
- Remember the divisor is always the number after the \div sign.

Step 3 Simplify (cancel) and then multiply to find the answer.

Step 4 Write the answer in lowest terms.

Example A: $\frac{3}{4} \div \frac{1}{2} = \square$

Step 1 No whole numbers or mixed numbers.

Step 2 $\frac{3}{4} \div \frac{1}{2} = \frac{3}{4} \times \frac{2}{1} = \square$

Step 3 and 4 $\frac{3}{\cancel{4}_2} \times \frac{\cancel{2}^1}{1} = \frac{3}{2} = 1\frac{1}{2}$

Example B: $\frac{7}{8} \div \frac{1}{4} = \square$

Step 1 No whole numbers or mixed numbers.

Step 2 $\frac{7}{8} \div \frac{1}{4} = \frac{7}{8} \times \frac{4}{1} = \square$

Step 3 and 4 $\frac{7}{\cancel{8}_2} \times \frac{\cancel{4}^1}{1} = \frac{7}{2} = 3\frac{1}{2}$

Example C: $5 \div \frac{2}{3} = \square$

Step 1 $5 \div \frac{2}{3} = \frac{5}{1} \div \frac{2}{3} = \square$

Step 2 $\frac{5}{1} \times \frac{3}{2} = \square$

Step 3 and 4 $\frac{5}{1} \times \frac{3}{2} = \frac{15}{2} = 7\frac{1}{2}$

Example D: $3\frac{1}{2} \div 2\frac{3}{4} = \square$

Step 1 $3\frac{1}{2} \div 2\frac{3}{4} = \frac{7}{2} \div \frac{11}{4} = \square$

Step 2 $\frac{7}{2} \times \frac{4}{11} = \square$

Step 3 and 4 $\frac{7}{\cancel{2}_1} \times \frac{\cancel{4}^2}{11} = \frac{14}{11} = 1\frac{3}{11}$

Exercise Two

Divide these fractions using the steps you have just learned.

a) $\frac{4}{9} \div 4 =$

$$\frac{4}{9} \div \frac{4}{1} = \frac{4}{9} \times \frac{1}{4} =$$

$$\frac{\cancel{4}^1}{9} \times \frac{1}{\cancel{4}_1} = \frac{1}{9}$$

b) $\frac{5}{8} \div \frac{10}{3} =$

c) $\frac{7}{2} \div \frac{3}{5} =$

d) $\frac{4}{5} \div \frac{6}{5} =$

e) $\frac{5}{8} \div \frac{7}{16} =$

f) $\frac{1}{2} \div \frac{3}{4} =$

g) $\frac{2}{3} \div \frac{8}{9} =$

h) $\frac{5}{8} \div \frac{4}{3} =$

i) $\frac{1}{5} \div \frac{1}{2} =$

j) $\frac{1}{4} \div \frac{2}{3} =$

k) $\frac{5}{6} \div \frac{5}{3} =$

l) $\frac{11}{12} \div \frac{5}{6} =$

m) $\frac{1}{3} \div \frac{3}{8} =$

n) $\frac{7}{12} \div \frac{5}{6} =$

o) $\frac{6}{7} \div \frac{1}{6} =$

p) $\frac{1}{8} \div \frac{5}{8} =$

Answers to Exercise Two

b) $\frac{3}{16}$

c) $5\frac{5}{6}$

d) $\frac{2}{3}$

e) $\frac{3}{7}$

f) $\frac{2}{3}$

g) $\frac{3}{4}$

h) $\frac{15}{32}$

i) $\frac{2}{5}$

j) $\frac{3}{8}$

k) $\frac{1}{2}$

l) $1\frac{1}{2}$

m) $\frac{8}{9}$

n) $\frac{7}{10}$

o) $5\frac{1}{7}$

p) $\frac{1}{5}$

Exercise Three

Do one quarter of these questions. If you are not having any trouble, go on to Exercise Four, which has mixed numbers in it. If you are having a harder time with this, do the remaining $\frac{3}{4}$ of the questions.

a) $\frac{1}{2} \div \frac{1}{8} =$

b) $\frac{8}{9} \div \frac{3}{2} =$

$$\frac{1}{2} \times \frac{8}{1} = \frac{1}{\cancel{2}_1} \times \frac{\cancel{8}^4}{1} = \frac{4}{1} = 4$$

c) $\frac{3}{4} \div \frac{3}{4} =$

d) $\frac{5}{6} \div \frac{3}{3} =$

e) $\frac{1}{3} \div \frac{3}{4} =$

f) $\frac{2}{3} \div \frac{1}{2} =$

g) $2 \div \frac{3}{5} =$

h) $\frac{5}{6} \div \frac{1}{3} =$

i) $3 \div \frac{1}{5} =$

j) $4 \div \frac{2}{3} =$

k) $\frac{3}{4} \div \frac{1}{8} =$

l) $3 \div \frac{1}{9} =$

m) $\frac{2}{3} \div \frac{1}{6} =$

n) $\frac{5}{6} \div \frac{1}{12} =$

o) $\frac{1}{2} \div \frac{2}{3} =$

p) $\frac{1}{2} \div \frac{1}{3} =$

q) $4 \div \frac{3}{4} =$

r) $\frac{1}{4} \div \frac{3}{5} =$

s) $\frac{7}{8} \div \frac{7}{12} =$

t) $\frac{1}{8} \div 2 =$

u) $3 \div \frac{4}{7} =$

v) $\frac{7}{8} \div \frac{1}{2} =$

$$w) \frac{2}{3} \div \frac{3}{4} =$$

$$x) \frac{1}{5} \div \frac{2}{3} =$$

$$y) 3 \div \frac{1}{4} =$$

$$z) \frac{5}{6} \div 10 =$$

Answers to Exercise Three

$$b) \frac{16}{27}$$

$$c) 1$$

$$d) \frac{5}{6}$$

$$e) \frac{4}{9}$$

$$f) 1\frac{1}{3}$$

$$g) 3\frac{1}{3}$$

$$h) 2\frac{1}{2}$$

$$i) 15$$

$$j) 6$$

$$k) 6$$

$$l) 27$$

$$m) 4$$

$$n) 10$$

$$o) \frac{3}{4}$$

$$p) 1\frac{1}{2}$$

$$q) 5\frac{1}{3}$$

$$r) \frac{5}{12}$$

$$s) 1\frac{1}{2}$$

$$t) \frac{1}{16}$$

$$u) 5\frac{1}{4}$$

$$v) 1\frac{3}{4}$$

$$w) \frac{8}{9}$$

$$x) \frac{3}{10}$$

$$y) 12$$

$$z) \frac{1}{12}$$

Exercise Four

More Practice: You might want to save some of this exercise to do as review before a test.

a) $8 \div \frac{1}{2} =$ _____

b) $2\frac{1}{3} \div 1\frac{1}{6} =$ _____

c) $2\frac{2}{5} \div \frac{1}{8} =$ _____

d) $\frac{1}{2} \div \frac{1}{4} =$ _____

e) $\frac{1}{6} \div \frac{1}{5} =$ _____

f) $3\frac{5}{8} \div \frac{1}{2} =$ _____

g) $\frac{1}{8} \div \frac{1}{5} =$ _____

h) $1\frac{1}{3} \div 2\frac{1}{4} =$ _____

i) $\frac{3}{5} \div \frac{1}{4} =$ _____

j) $5 \div 3\frac{2}{3} =$ _____

k) $2\frac{4}{5} \div \frac{1}{5} =$ _____

l) $\frac{5}{9} \div \frac{1}{3} =$ _____

m) $\frac{2}{5} \div \frac{1}{2} =$ _____

n) $\frac{5}{6} \div 10 =$ _____

o) $\frac{1}{4} \div \frac{2}{3} =$ _____

p) $1\frac{1}{3} \div 3\frac{2}{3} =$ _____

q) $2\frac{3}{4} \div 1\frac{7}{8} =$ _____

r) $3\frac{5}{6} \div 1\frac{2}{3} =$ _____

s) $5\frac{1}{10} \div 3\frac{3}{10} =$ _____

t) $2\frac{3}{8} \div 1\frac{5}{16} =$ _____

u) $1\frac{5}{9} \div 3\frac{1}{3} =$ _____

v) $\frac{3}{4} \div \frac{1}{2} =$ _____

w) $\frac{1}{2} \div \frac{3}{8} =$ _____

x) $\frac{1}{3} \div \frac{1}{5} =$ _____

y) $\frac{1}{5} \div \frac{3}{4} =$ _____

z) $3\frac{3}{4} \div 2\frac{1}{8} =$ _____

Answers to Exercise Four

- | | | | | | |
|--------------------|---------------------|--------------------|--------------------|--------------------|--------------------|
| a) 16 | b) 2 | c) $19\frac{1}{5}$ | d) 2 | e) $\frac{5}{6}$ | f) $7\frac{1}{4}$ |
| g) $\frac{5}{8}$ | h) $\frac{16}{27}$ | i) $2\frac{2}{5}$ | j) $1\frac{4}{11}$ | k) 14 | l) $1\frac{2}{3}$ |
| m) $\frac{4}{5}$ | n) $\frac{1}{12}$ | o) $\frac{3}{8}$ | p) $\frac{4}{11}$ | q) $1\frac{7}{15}$ | r) $2\frac{3}{10}$ |
| s) $1\frac{6}{11}$ | t) $1\frac{17}{21}$ | u) $\frac{7}{15}$ | v) $1\frac{1}{2}$ | w) $1\frac{1}{3}$ | x) $1\frac{2}{3}$ |
| y) $\frac{4}{15}$ | z) $1\frac{13}{17}$ | | | | |

Problems Which Use Division of Common Fractions

Look for word patterns and key words in the division problems. Thinking about the problems using whole numbers instead of fractions may sometimes help you to recognize the division pattern. Start your division equation with the dividend. The dividend is the total amount.

These key words often point to division:

separated split cut shared

What is cost per...? unit pricing

What is distance per...? average (speed, cost, weight, time)

Exercise Five

Solve the problems.

- a) Every fall three friends get together to make antipasta. Last year they filled $4\frac{1}{2}$ ice cream buckets with antipasta and then shared it equally. How many buckets of antipasta did each person get?

- b) A pick-up truck load of split wood is $\frac{1}{2}$ cord of wood. If you shared a full truck load of wood with a neighbour, how much of a cord of firewood would you each get?

- c) The distance from Trail, B.C. to Vancouver, B.C. is 640 kilometres via the Crowsnest Highway. The trip can be made in $7\frac{1}{2}$ hours in good weather. What average speed must be maintained?
- d) The sweater that Janet is knitting has a complicated pattern. It takes her $3\frac{3}{4}$ hours to finish 15 rows. How long does each row take?
- e) Marian had $1\frac{2}{3}$ lemon pies left which she wanted to share equally amongst 10 people. How much of a pie will each person be given?
- f) Jack wants to cut his piece of trim for his square windows into 4 equal parts. The trim is $2\frac{2}{5}$ metres long. What will the measurement be of each piece?

g) Joni is sewing 3 identical pairs of pants for her son's dance performance. She has bought $5\frac{1}{3}$ meters of material. She uses up all the material, how much material was used in each pair of pants?

h) Joy has a $7\frac{1}{4}$ m long stick. She needs to split it into $\frac{1}{3}$ m pieces. How many pieces can she get? (remember: your answer will be given with the unit of 'pieces' not metres!)

Answers to Exercise Five

a) $1\frac{1}{2}$ buckets b) $\frac{1}{4}$ cord c) $85\frac{1}{3}$ km/h ($85.\bar{3}$ km/h)

d) $\frac{1}{4}$ hour or 15 minutes e) $\frac{1}{6}$ pie

f) each piece is $\frac{3}{5}$ metres long g) She uses $1\frac{7}{9}$ meter for each pair

h) She will get 21 pieces

Topic B: Self-Test

Mark /10 Aim 8/10

A. Divide and be sure the answers are in lowest terms.

8 marks

a) $\frac{3}{4} \div \frac{1}{4} =$ _____

b) $\frac{1}{4} \div 1\frac{1}{4} =$ _____

c) $\frac{5}{8} \div \frac{15}{16} =$ _____

d) $6 \div \frac{7}{9} =$ _____

e) $\frac{5}{11} \div 11 =$ _____

f) $9\frac{3}{4} \div 2 =$ _____

g) $3 \div 4\frac{1}{3} =$ _____

h) $3\frac{3}{7} \div 2\frac{5}{14} =$ _____

B. Word Problem

2 marks

- a) Joe is a school janitor. It takes him $\frac{3}{4}$ of an hour to clean one classroom. How many classrooms does he clean in his $7\frac{1}{2}$ hour shift.

Answers to Topic B Self-Test

A.

- a) 3 b) $\frac{1}{5}$ c) $\frac{2}{3}$ d) $7\frac{5}{7}$ e) $\frac{5}{121}$ f) $4\frac{7}{8}$
g) $\frac{9}{13}$ h) $1\frac{5}{11}$

B.

- a) 10 classrooms

Unit 3 Review

1. Write the multiplication equation you would use to find the fraction of the whole number. You do not have to calculate the answers.

a) More than $\frac{1}{3}$ of the children at the day care are sick today. There are 15 children in the day care. How many children are sick?

b) Rich answered $\frac{7}{8}$ of the questions on the test. The test had 48 questions. How many questions did Rich complete?

c) **Canada Post delivers more than** 11.6 billion pieces of mail across Canada in 2008. They have a target of getting $\frac{96}{100}$ letters delivered on time. How many letters got delivered on time in 2008?

- d) We spend $\frac{1}{6}$ of our monthly income on food. Our take home pay is \$1400. How much does our food cost each month?

2. Write the multiplication equation you would use to multiply a fraction by a whole number. You do not have to calculate the answer.

- a) We want to buy a good bottle of wine for dinner, but there are 4 bottles of wine from last night that are not used up yet. Let's take each $\frac{1}{6}$ bottle of wine that is left over and have that at dinner tonight. How much wine will we have?

- b) There are four boxes of cereal open in the cupboard and each one is $\frac{3}{4}$ full. How many full boxes would there be, if they were all put together?

- c) Double a recipe that needs $\frac{1}{3}$ tsp of cinnamon.

- d) Your friend is a frequent coffee drinker at the local coffee shop. He has a punch card, and gets a hole punched out each time he buys a coffee. Once he has a card with 14 holes punched out, he gets a free coffee. He keeps losing his card, and getting a new one. He has found them all, and he now has 3 cards, each with $\frac{2}{5}$ of the holes punched out. Does he have enough holes punched out to get a free coffee?

3. Multiply these fractions:

a) $7 \times \frac{2}{3} =$ _____

b) $3 \times \frac{2}{5} =$ _____

c) $\frac{1}{2} \times 14 =$ _____

d) $\frac{3}{8} \times 4 =$ _____

e) $5 \times \frac{1}{5} =$ _____

f) $3 \times \frac{3}{4} =$ _____

g) $\frac{3}{2} \times 20 =$ _____

h) $4 \times \frac{2}{3} =$ _____

i) $\frac{3}{8}$ of 6 = _____

j) $\frac{5}{6}$ of 4 = _____

4. Multiply these fractions

a) $\frac{1}{6} \times \frac{1}{4} =$ _____

b) $\frac{3}{4} \times \frac{5}{6} =$ _____

c) $\frac{5}{10} \times \frac{1}{3} =$ _____

d) $\frac{1}{8} \times \frac{2}{5} =$ _____

e) $\frac{1}{4} \times \frac{1}{7} =$ _____

f) $\frac{4}{9} \times \frac{1}{7} =$ _____

g) $\frac{7}{10} \times \frac{2}{3} =$ _____

h) $\frac{8}{9} \times \frac{2}{3} =$ _____

5. Multiply these fractions. Simplify before multiplying, where possible.

a) $\frac{2}{5} \times \frac{15}{7} =$ _____

b) $\frac{5}{8} \times \frac{1}{10} =$ _____

c) $\frac{3}{4} \times \frac{1}{9} =$ _____

d) $\frac{7}{8} \times \frac{12}{14} =$ _____

e) $\frac{8}{9} \times \frac{1}{4} =$ _____

f) $\frac{1}{2} \times \frac{2}{7} \times \frac{5}{7} =$ _____

g) $\frac{3}{5} \times \frac{2}{9} \times \frac{1}{2} =$ _____

h) $2 \times \frac{3}{7} \times \frac{5}{12} =$ _____

6. Multiply these fractions. Simplify before multiplying, where possible.

a) $7\frac{1}{3} \times \frac{3}{7} =$ _____

b) $\frac{5}{7} \times 56 =$ _____

c) $3\frac{1}{4} \times 3\frac{1}{2} =$ _____

d) $6\frac{2}{3} \times 2\frac{1}{2} =$ _____

e) $2\frac{1}{5} \times \frac{5}{6} =$ _____

f) $7\frac{2}{3} \times \frac{3}{4} =$ _____

g) $9 \times \frac{2}{3} =$ _____

h) $3\frac{1}{3} \times 3\frac{1}{4} =$ _____

i) $4 \times \frac{5}{6} =$ _____

j) $6\frac{1}{3} \times \frac{5}{6} =$ _____

7. Solve the following word problems:

- a) A recipe calls for $\frac{2}{3}$ of a cup of sugar. How much sugar should be used if only $\frac{1}{2}$ the recipe is being made?

b) The Wrights sold their house for \$240 000. The real estate company that helped them sell their house gets $\frac{3}{20}$ of this amount. How much money did the Wrights have to pay the real estate company?

c) Find the area of the rectangle

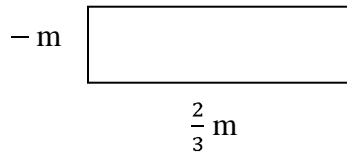

d) Each turn of a screw sinks it $\frac{1}{2}$ of a centimetre deeper into the wood. Find out how deep the screw is after 7 turns.

e) $\frac{3}{4}$ of 48 students in the gym are girls. How many girls are in the gym?

8. Divide these fractions. Simplify before multiplying, where possible.

a) $\frac{7}{2} \div \frac{3}{4} =$ _____

b) $\frac{4}{10} \div \frac{6}{5} =$ _____

c) $\frac{5}{8} \div \frac{7}{24} =$ _____

d) $\frac{1}{8} \div \frac{3}{4} =$ _____

e) $\frac{2}{3} \div \frac{7}{9} =$ _____

f) $\frac{5}{8} \div \frac{4}{7} =$ _____

g) $\frac{1}{5} \div \frac{1}{4} =$ _____

h) $\frac{3}{4} \div \frac{2}{3} =$ _____

i) $\frac{5}{6} \div \frac{5}{3} =$ _____

j) $\frac{11}{15} \div \frac{5}{6} =$ _____

9. Divide these fractions. Simplify before multiplying, where possible.

a) $2\frac{4}{5} \div \frac{1}{5} =$ _____

b) $\frac{5}{9} \div \frac{1}{3} =$ _____

c) $\frac{2}{5} \div \frac{1}{2} =$ _____

d) $\frac{5}{6} \div 10 =$ _____

e) $\frac{1}{4} \div \frac{2}{3} =$ _____

f) $1\frac{1}{3} \div 3\frac{2}{3} =$ _____

g) $2\frac{3}{4} \div 1\frac{7}{8} =$ _____

h) $3\frac{5}{6} \div 1\frac{2}{3} =$ _____

i) $5\frac{1}{10} \div 3\frac{3}{10} =$ _____

j) $2\frac{3}{8} \div 1\frac{5}{16} =$ _____

10. Solve the following word problems:

a) If you want to share $3\frac{1}{3}$ cups of juice between 4 children, how much juice does each child get?

b) Aaron ran $24\frac{3}{4}$ km in 3 days. How many kilometres did he run each day?

c) Jordan is selling falafel at Music Fest this summer. She made $48\frac{3}{4}$ kg of falafel mix.
How many $\frac{1}{16}$ kg falafel balls can she make?

d) Sophie has a $75\frac{1}{4}$ cm a piece of wood trim. She wants to cut it into $3\frac{1}{2}$ cm pieces. How many pieces can she get?

Answers to Review and Extra Practice

- 1** a) $\frac{1}{3} \times \frac{15}{1}$ b) $\frac{7}{8} \times \frac{48}{1}$ c) $\frac{96}{100} \times \frac{11.6}{1}$ billion d) $\frac{1}{6} \times \frac{1400}{1}$
- 2** a) $4 \times \frac{1}{6}$ b) $4 \times \frac{3}{4}$ c) $2 \times \frac{1}{3}$ d) $3 \times \frac{2}{5}$
- 3** a) $4\frac{2}{3}$ b) $1\frac{1}{5}$ c) 7 d) $1\frac{1}{2}$ e) 1 f) $2\frac{1}{4}$
 g) 30 h) $2\frac{2}{3}$ i) $2\frac{1}{4}$ j) $3\frac{1}{3}$
- 4** a) $\frac{1}{24}$ b) $\frac{5}{8}$ c) $\frac{1}{6}$ d) $\frac{1}{20}$ e) $\frac{1}{28}$ f) $\frac{4}{63}$
 g) $\frac{7}{15}$ h) $\frac{16}{27}$
- 5** a) $\frac{6}{7}$ b) $\frac{1}{16}$ c) $\frac{1}{12}$ d) $\frac{3}{4}$ e) $\frac{2}{9}$ f) $\frac{5}{14}$
 g) $\frac{1}{15}$ h) $\frac{5}{14}$
- 6** a) $3\frac{1}{7}$ b) 40 c) 11 d) $16\frac{2}{3}$ e) $1\frac{5}{6}$ f) $5\frac{3}{4}$
 g) 6 h) $10\frac{5}{6}$ i) $3\frac{1}{3}$ j) $5\frac{5}{18}$
- 7** a) $\frac{1}{3}$ cup sugar b) \$36 000 c) $\frac{1}{6}$ m d) $3\frac{1}{2}$ cm e) 36 students
- 8** a) $4\frac{2}{3}$ b) $\frac{2}{6}$ c) $2\frac{1}{7}$ d) $\frac{1}{6}$ e) $\frac{6}{7}$ f) $\frac{5}{14}$
 g) $\frac{4}{5}$ h) $1\frac{1}{8}$ i) $\frac{1}{2}$ j) $\frac{22}{25}$
- 9** a) 14 b) $1\frac{2}{3}$ c) $\frac{4}{5}$ d) $\frac{1}{12}$ e) $\frac{3}{8}$ f) $\frac{4}{11}$
 g) $\frac{11}{15}$ h) $\frac{23}{10}$ i) $1\frac{6}{11}$ j) $\frac{5}{8}$
- 10** a) $\frac{5}{6}$ cups each b) $8\frac{1}{4}$ km in one day c) 780 balls of falafel d) $21\frac{1}{2}$ pieces

It is now test time!

Please get the practice test
from your instructor.

Once you are ready, you can get
the unit 3 test from your instructor.

Good luck!

Unit 4

Adding & Subtracting Common Fractions

Topic A: Adding Common Fractions

Vocabulary Review:

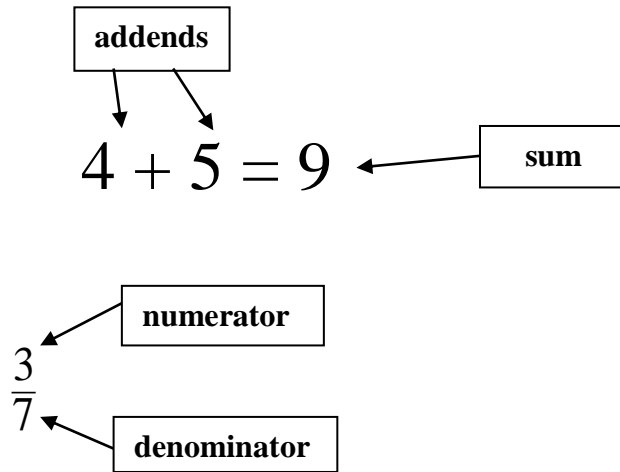

Like Fractions: Fractions that have the same denominator

Example: $\frac{1}{4}$ $\frac{2}{4}$ $\frac{3}{4}$ $\frac{4}{4}$ etc

Adding and subtracting fractions has some different rules from multiplying and dividing.



There are two cakes that are left over. There is 1 piece of each cake left. If you were to put all the pieces left onto one plate, how much cake would you have?

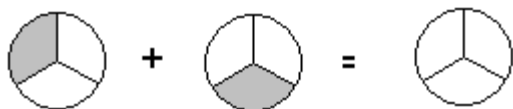

Shade in your answer here

If you made your plate like this:



then you are right!

Try this example:

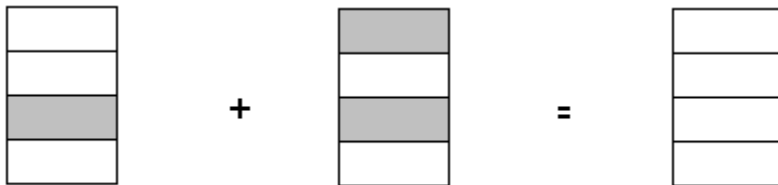

The answer is:

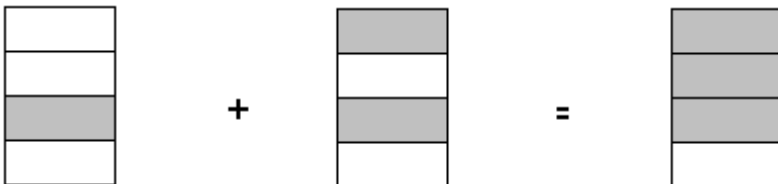

What you are doing is adding two like fractions.

- You are moving pieces of fractions that are the same size into one whole shape. The pieces do not change size, so **the denominator must stay the same size**.
- When adding two fractions, your answer is a fraction.

Look back at the two examples.

When you add fractions, does the denominator or the numerator stay the same? _____

Common fractions must have the same denominator when you add them together.
Add the numerators and keep the denominators the same.

Look at the next two examples:

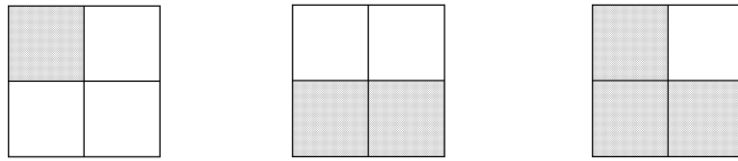

$$\frac{1}{4} + \frac{2}{4} = \frac{3}{4}$$



$$\frac{1}{5} + \frac{2}{5} + \frac{1}{5} = \frac{4}{5}$$

Exercise One Try a few for yourself

a)

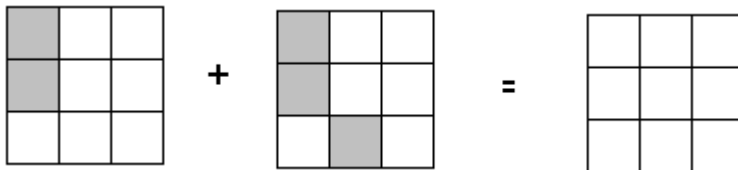

$$\frac{2}{9} + \frac{3}{9} = \frac{5}{9}$$

b)

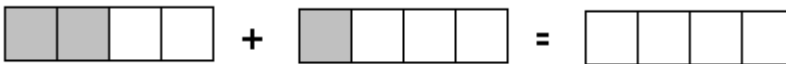

$$\frac{2}{4} + \frac{1}{4} = \frac{3}{4}$$

c)

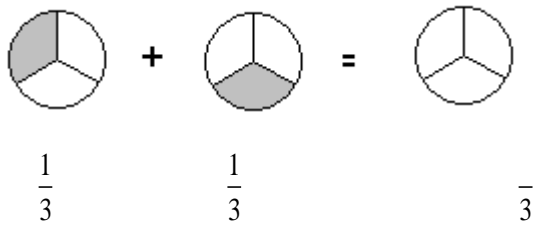

d)

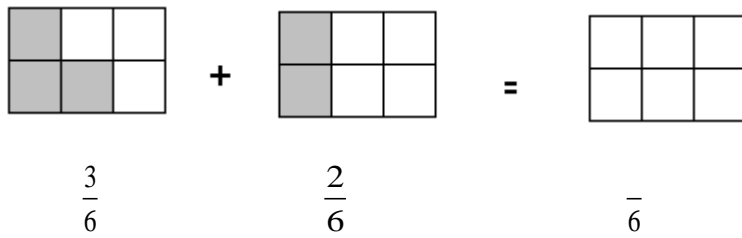

e)

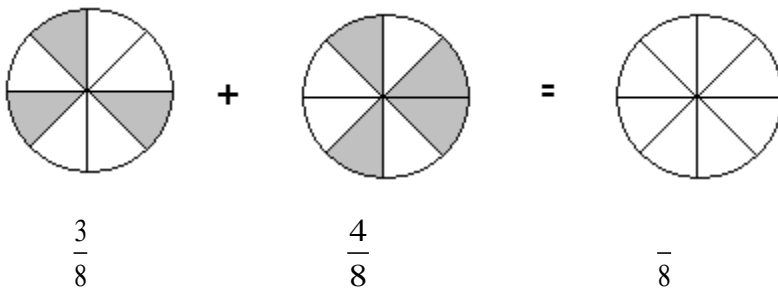

Answers to Exercise One

a) $\frac{5}{9}$

b) $\frac{3}{4}$

c) $\frac{2}{3}$

d) $\frac{5}{6}$

e) $\frac{7}{8}$

Exercise Two

Now find the answers to the additions without diagrams.

$$\text{a) } \frac{2}{4} + \frac{1}{4} = \frac{\quad}{4}$$

$$\text{b) } \frac{3}{5} + \frac{1}{5} = \frac{\quad}{5}$$

$$\text{c) } \frac{1}{3} + \frac{1}{3} = \frac{\quad}{3}$$

$$\text{d) } \frac{1}{7} + \frac{3}{7} = \frac{\quad}{7}$$

$$\text{e) } \frac{1}{5} + \frac{1}{5} = \frac{\quad}{5}$$

$$\text{f) } \frac{3}{8} + \frac{4}{8} = \frac{\quad}{8}$$

$$\text{g) } \frac{2}{11} + \frac{7}{11} = \frac{\quad}{11}$$

$$\text{h) } \frac{3}{22} + \frac{4}{22} = \frac{\quad}{22}$$

Answers to Exercise Two

$$\text{a) } \frac{3}{4}$$

$$\text{b) } \frac{4}{5}$$

$$\text{c) } \frac{2}{3}$$

$$\text{d) } \frac{4}{7}$$

$$\text{e) } \frac{2}{5}$$

$$\text{f) } \frac{7}{8}$$

$$\text{g) } \frac{9}{11}$$

$$\text{h) } \frac{7}{22}$$

Exercise Three

Add these common fractions.

$$\text{a) } \frac{1}{5} + \frac{2}{5} =$$

$$\text{b) } \frac{3}{6} + \frac{2}{6} =$$

$$\text{c) } \frac{1}{4} + \frac{2}{4} =$$

$$\text{d) } \frac{3}{7} + \frac{2}{7} =$$

$$\text{e) } \frac{3}{10} + \frac{6}{10} =$$

$$\text{f) } \frac{4}{9} + \frac{1}{9} =$$

$$\text{g) } \frac{14}{20} + \frac{3}{20} =$$

$$\text{h) } \frac{7}{37} + \frac{19}{37} =$$

$$\text{i) } \frac{1}{49} + \frac{42}{49} =$$

$$\text{j) } \frac{100}{123} + \frac{17}{123} =$$

Answers to Exercise Three

$$\text{a) } \frac{3}{5}$$

$$\text{b) } \frac{5}{6}$$

$$\text{c) } \frac{3}{4}$$

$$\text{d) } \frac{5}{7}$$

$$\text{e) } \frac{9}{10}$$

$$\text{f) } \frac{5}{9}$$

$$\text{g) } \frac{17}{20}$$

$$\text{h) } \frac{26}{37}$$

$$\text{i) } \frac{43}{49}$$

$$\text{j) } \frac{117}{123}$$



Sometimes the sum of a fraction will need to be reduced. (take a look at this example to remind yourself how to do this)

Example 1: $\frac{2}{8} + \frac{2}{8} = \frac{4}{8} \longrightarrow \frac{4}{8} \begin{smallmatrix} \div 4 \\ \div 4 \end{smallmatrix} = \frac{1}{2}$

Example 2: $\frac{3}{4} + \frac{3}{4} = \frac{6}{4} \longrightarrow \frac{6}{4} \begin{smallmatrix} \div 2 \\ \div 2 \end{smallmatrix} = \frac{3}{2} = 1\frac{1}{2}$

Exercise Four

Find the sums to the following additions. Make sure your answer is in the lowest terms.

a) $\frac{1}{4} + \frac{1}{4} =$

b) $\frac{1}{3} + \frac{1}{3} =$

c) $\frac{2}{8} + \frac{4}{8} =$

d) $\frac{3}{10} + \frac{2}{10} =$

e) $\frac{7}{25} + \frac{8}{25} =$

f) $\frac{1}{9} + \frac{2}{9} =$

g) $\frac{3}{5} + \frac{1}{5} =$

h) $\frac{9}{27} + \frac{12}{27} =$

i) $\frac{1}{6} + \frac{1}{6} =$

j) $\frac{3}{12} + \frac{6}{12} =$

Answers to Exercise Four

a) $\frac{1}{2}$

b) $\frac{2}{3}$

c) $\frac{3}{4}$

d) $\frac{1}{2}$

e) $\frac{3}{5}$

f) $\frac{1}{3}$

g) $\frac{4}{5}$

h) $\frac{7}{9}$

i) $\frac{1}{3}$

j) $\frac{3}{4}$



So far all your answers have been less than one (a proper fraction). Sometimes adding fractions can result in more than one whole.

Look at this example:

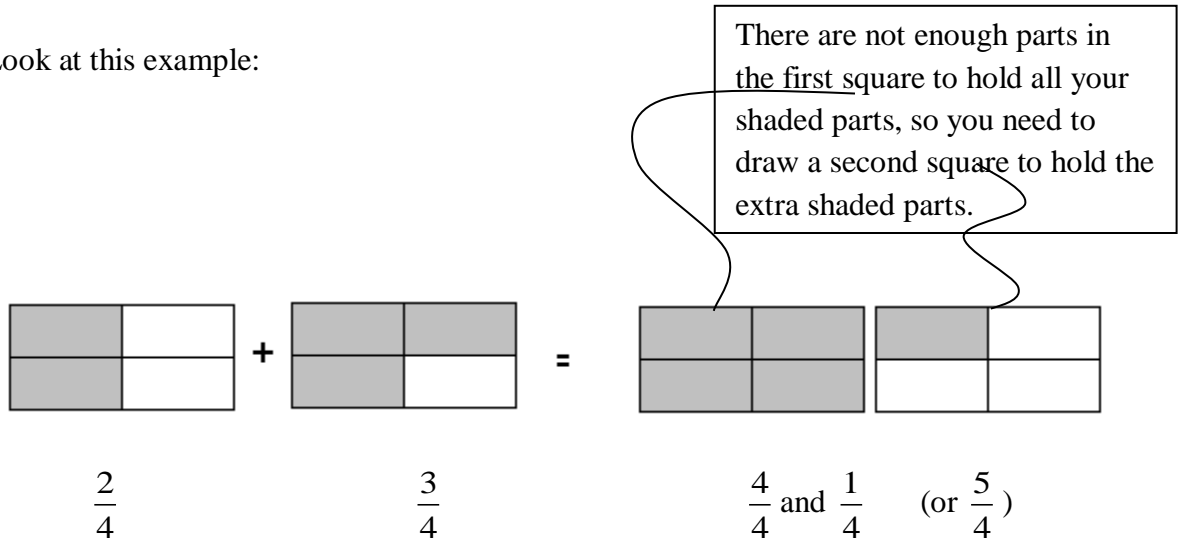

You would also have to convert this answer from an improper fraction to a mixed number:

$$\frac{5}{4} = 1\frac{1}{4}$$

Exercise Five

Try these additions (remember to always reduce your answer to lowest terms).

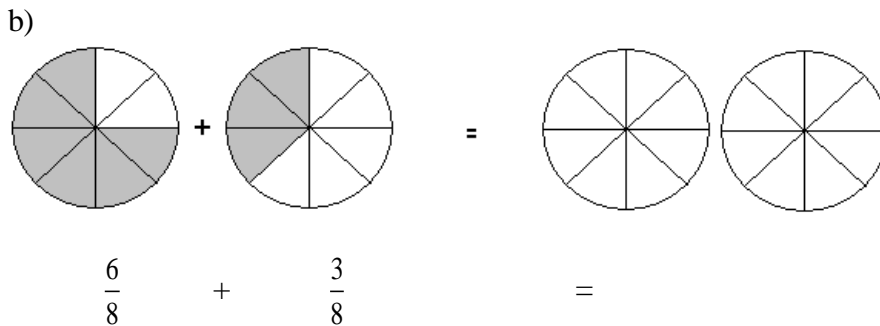
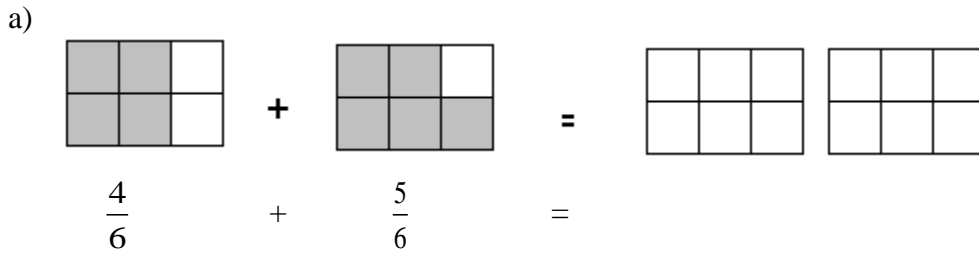

c)

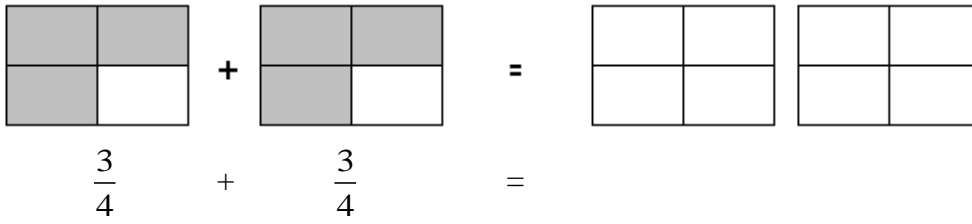

d)

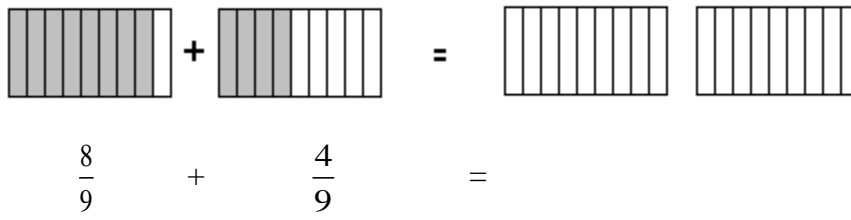

e)

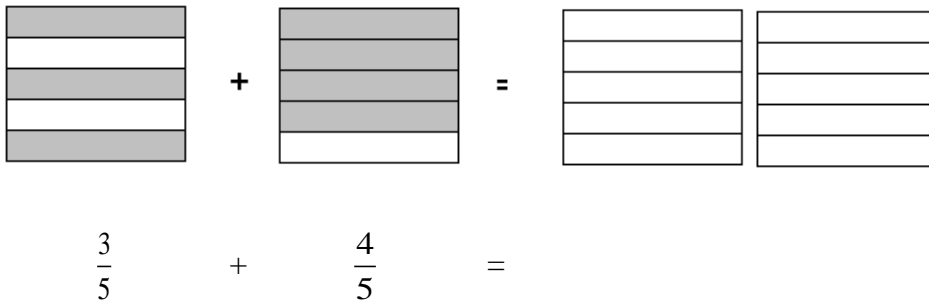

Answers to Exercise Five

a) $1 \frac{1}{2}$ b) $1 \frac{1}{8}$ c) $1 \frac{1}{2}$ d) $1 \frac{1}{3}$ e) $1 \frac{3}{5}$

Sometimes you will have to add 3 or more fractions together.

Example A:

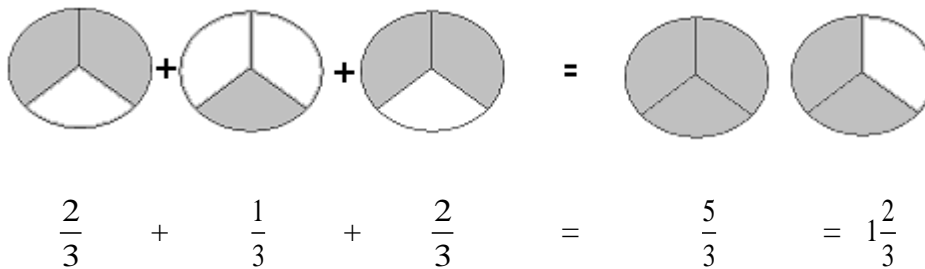

Example B:

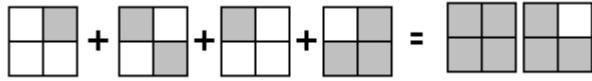

$$\frac{1}{4} + \frac{2}{4} + \frac{1}{4} + \frac{3}{4} = \frac{7}{4} = 1\frac{3}{4}$$

Exercise Six

Add these common fractions. Be sure your answers are in lowest terms.

a) $\frac{2}{3} + \frac{1}{3} = \frac{3}{3} = 1$

b) $\frac{3}{5} + \frac{4}{5} =$

c) $\frac{7}{10} + \frac{3}{10} =$

d) $\frac{1}{4} + \frac{1}{4} =$

e) $\frac{3}{5} + \frac{2}{5} =$

f) $\frac{3}{8} + \frac{2}{8} =$

g)
$$\begin{array}{r} \frac{3}{4} \\ + \frac{1}{4} \\ \hline \end{array}$$

h)
$$\begin{array}{r} \frac{5}{6} \\ + \frac{5}{6} \\ \hline \end{array}$$

i)
$$\begin{array}{r} \frac{3}{5} \\ + \frac{1}{5} \\ \hline \end{array}$$

$$\begin{array}{r} \text{j) } \frac{4}{8} \\ + \frac{3}{8} \\ \hline \end{array}$$

$$\begin{array}{r} \text{k) } \frac{1}{2} \\ + \frac{1}{2} \\ \hline \end{array}$$

$$\begin{array}{r} \text{l) } \frac{7}{9} \\ + \frac{4}{9} \\ \hline \end{array}$$

$$\begin{array}{r} \text{m) } \frac{1}{8} \\ + \frac{3}{8} \\ \hline \end{array}$$

$$\begin{array}{r} \text{n) } \frac{2}{10} \\ + \frac{1}{10} \\ + \frac{3}{10} \\ \hline \end{array}$$

$$\begin{array}{r} \text{o) } \frac{2}{8} \\ + \frac{3}{8} \\ + \frac{1}{8} \\ \hline \end{array}$$

$$\begin{array}{r} \text{p) } \frac{2}{5} \\ + \frac{3}{5} \\ \hline \end{array}$$

$$\begin{array}{r} \text{q) } \frac{3}{6} \\ + \frac{1}{6} \\ \hline \end{array}$$

Answers to Exercise Six

$$\text{b) } 1\frac{2}{5}$$

$$\text{c) } 1$$

$$\text{d) } \frac{1}{2}$$

$$\text{e) } 1$$

$$\text{f) } \frac{5}{8}$$

$$\text{h) } 1\frac{2}{3}$$

$$\text{i) } \frac{4}{5}$$

$$\text{j) } \frac{7}{8}$$

$$\text{k) } 1$$

$$\text{l) } 1\frac{2}{9}$$

$$\text{m) } \frac{1}{2}$$

$$\text{n) } \frac{3}{5}$$

$$\text{o) } \frac{3}{4}$$

$$\text{p) } 1\frac{3}{5}$$

$$\text{q) } \frac{5}{6}$$

Adding Mixed Numbers

To add mixed numbers

- Be sure the denominators are the same.
- Add the common fractions.
- Add the whole numbers.
- Simplify the common fraction.

Example A:

$$\begin{array}{r} 3\frac{1}{8} \\ + 2\frac{3}{8} \\ \hline \end{array}$$

$$5\frac{4}{8} = 5\frac{1}{2}$$

$$\frac{4}{8} = \frac{4}{8} \left(\frac{\div 4}{\div 4} \right) = \frac{1}{2}$$

Example B:

$$\begin{array}{r} 12\frac{1}{3} \\ + 6\frac{1}{3} \\ \hline 18\frac{2}{3} \end{array}$$

Exercise Seven

Add the following numbers. Reduce the answers to lowest terms.

a)

$$\begin{array}{r} 6\frac{1}{12} \\ + 8\frac{5}{12} \\ \hline \end{array}$$

$$14\frac{6}{12} = 14\frac{1}{2}$$

b)

$$\begin{array}{r} 3\frac{2}{9} \\ + 4\frac{4}{9} \\ \hline \end{array}$$

c)

$$\begin{array}{r} 22\frac{1}{6} \\ + 14\frac{1}{6} \\ \hline \end{array}$$

d)

$$\begin{array}{r} 7\frac{1}{8} \\ + 1\frac{1}{8} \\ \hline \end{array}$$

e)

$$\begin{array}{r} 8\frac{1}{4} \\ + 3\frac{1}{4} \\ \hline \end{array}$$

f)

$$\begin{array}{r} 3\frac{2}{5} \\ + 1\frac{1}{5} \\ \hline \end{array}$$

g)

$$\begin{array}{r} 18\frac{1}{2} \\ + 10 \\ \hline \end{array}$$

h)

$$\begin{array}{r} 4\frac{1}{10} \\ + \frac{3}{10} \\ \hline \end{array}$$

i)

$$\begin{array}{r} 7\frac{1}{8} \\ + 1\frac{1}{8} \\ \hline \end{array}$$

Answers to Exercise Seven

b) $7\frac{2}{3}$

c) $36\frac{1}{3}$

d) $8\frac{1}{4}$

e) $11\frac{1}{2}$

f) $3\frac{3}{5}$

g) $28\frac{1}{2}$

h) $4\frac{2}{5}$

i) $15\frac{5}{7}$

Exercise Eight

Add these numbers. Give your answers in lowest terms.

a)

$$\begin{array}{r} 6\frac{4}{5} \\ + 3\frac{2}{5} \\ \hline \end{array}$$

$$9\frac{6}{5} = 10\frac{1}{5}$$

b)

$$\begin{array}{r} 9\frac{1}{3} \\ + 2\frac{2}{3} \\ \hline \end{array}$$

c)

$$\begin{array}{r} 3\frac{3}{8} \\ + 12\frac{7}{8} \\ \hline \end{array}$$

d)

$$\begin{array}{r} 1\frac{1}{2} \\ + 2\frac{1}{2} \\ \hline \end{array}$$

e)

$$\begin{array}{r} 100\frac{7}{10} \\ + 50\frac{5}{10} \\ \hline \end{array}$$

f)

$$\begin{array}{r} 10\frac{1}{4} \\ + 6\frac{3}{4} \\ \hline \end{array}$$

g)

$$\begin{array}{r} 3\frac{4}{7} \\ + 6\frac{5}{7} \\ \hline \end{array}$$

h)

$$\begin{array}{r} 8\frac{4}{5} \\ + 3\frac{4}{5} \\ \hline \end{array}$$

i)

$$\begin{array}{r} 8\frac{2}{4} \\ 9\frac{1}{4} \\ + 3\frac{1}{4} \\ \hline \end{array}$$

Answers to Exercise Eight

b) 12

c) $16\frac{1}{4}$

d) 4

e) $151\frac{1}{5}$

f) 17

g) $10\frac{2}{7}$

h) $12\frac{3}{5}$

i) 21



If you are not comfortable with this work so far, talk to your instructor and get some more practice before you go ahead.

The next question is:

What happens when two fractions in an addition (the addends) do not have the same denominator?

If the addends do not have a common denominator, you will need to find equivalent fractions to make the addends have a common denominator.

Read on to find out how!

Multiples and Least Common Multiples (L.C.M.)

When you learned the multiplication tables you learned the **multiples** of each number. Multiples are the answers when you multiply a whole number by 1, 2, 3, 4, 5, 6, 7, and so on.

The **multiples of 2**

$$2 \times 1 = 2$$

$$2 \times 2 = 4$$

$$2 \times 3 = 6$$

$$2 \times 4 = 8$$

$$2 \times 5 = 10$$

$$2 \times 6 = 12$$

$$2 \times 7 = 14$$

$$2 \times 8 = 16$$

$$2 \times 9 = 18$$

$$2 \times 10 = 20$$

$$2 \times 11 = 22$$

$$2 \times 12 = 24$$

The **multiples of 6**

$$6 \times 1 = 6$$

$$6 \times 2 = 12$$

$$6 \times 3 = 18$$

$$6 \times 4 = 24$$

$$6 \times 5 = 30$$

$$6 \times 6 = 36$$

$$6 \times 7 = 42$$

$$6 \times 8 = 48$$

$$6 \times 9 = 54$$

$$6 \times 10 = 60$$

$$6 \times 11 = 66$$

$$6 \times 12 = 72$$

and you can keep going as high as you want.

The multiples of 2 are **2, 4, 6, 8, 10, 12, 14**, and so on.

The multiples of 6 are **6, 12, 18, 24, 30, 36**, and so on.

Exercise Nine

List the first ten multiples of each number. This chart may be useful to you later.

| | Number | Multiples |
|----|--------|------------------------------------|
| a) | 2 | 2, 4, 6, 8, 10, 12, 14, 16, 18, 20 |
| b) | 3 | |
| c) | 4 | |
| d) | 5 | |
| e) | 6 | |
| f) | 7 | |
| g) | 8 | |
| h) | 9 | |
| i) | 10 | |
| j) | 11 | |
| k) | 12 | |

Answers to Exercise Nine

b) 3, 6, 9, 12, 15, 18, 21, 24, 27, 30

d) 5, 10, 15, 20, 25, 30, 35, 40, 45, 50

f) 7, 14, 21, 28, 35, 42, 49, 56, 63, 70

h) 9, 18, 27, 36, 45, 54, 63, 72, 81, 90

j) 11, 22, 33, 44, 55, 66, 77, 88, 99, 110

c) 4, 8, 12, 16, 20, 24, 28, 32, 36, 40

e) 6, 12, 18, 24, 30, 36, 42, 48, 54, 60

g) 8, 16, 24, 32, 40, 48, 56, 64, 72, 80

i) 10, 20, 30, 40, 50, 60, 70, 80, 90, 100

k) 12, 24, 36, 48, 60, 72, 84, 96, 108, 120

This is a quick method to find the **least common multiple (LCM)**.

least means **smallest**

common means **shared**

multiple means the **answers** when you **multiply** by 1, 2, 3, etc.

Example A: What is the **least common multiple (LCM)** of 3 and 5?

- Multiples:
Multiples of 3: 3, 6, 9, 12, 15, 18, 21, 24, 27, 30...
Multiples of 5: 5, 10, 15, 20, 25, 30...

• The **least common multiple** of 3 and 5 is **15**.

Example B: What is the LCM of 3 and 4?

- Multiples:
Multiples of 3: 3, 6, 9, 12, 15, 18, 21, 24, 27, 30...
Multiples of 4: 4, 8, 12, 16, 20, 24, 28, 32

• The **least common multiple** of 3 and 4 is **12**.

Example C: What is the LCM of 4 and 8?

- Multiples:
Multiples of 4: 4, 8, 12, 16, 20...
Multiples of 8: 8, 16, 24, 32, 40...

• The **least common multiple** of 4 and 8 is **8**.



Hint: Always check to see if the larger number is a multiple of the smaller number. If it is, then the larger number is the least common multiple.

LCM of 3 and 6 is 6

LCM of 2 and 4 is 4

LCM of 5 and 15 is 15

Exercise Ten

Find the least common multiple of these pairs of numbers. Use your chart from Exercise Four to help you. You may want to add the multiples of other numbers to that chart.

- a) 3, 6 _____ b) 2, 5 _____ c) 4, 12 _____
- d) 12, 3 _____ e) 6, 12 _____ f) 8, 2 _____
- g) 5, 4 _____ h) 4, 8 _____ i) 8, 10 _____
- j) 8, 16 _____ k) 4, 7 _____ l) 8, 24 _____
- m) 25, 5 _____ n) 2, 9 _____ o) 3, 7 _____
- p) 6, 10 _____ q) 8, 12 _____ r) 7, 14 _____

Answers to Exercise Ten

- | | | | |
|-------|-------|-------|-------|
| a) 6 | b) 10 | c) 12 | d) 12 |
| e) 12 | f) 8 | g) 20 | h) 8 |
| i) 40 | j) 16 | k) 28 | l) 24 |
| m) 25 | n) 18 | o) 21 | p) 30 |
| q) 24 | r) 14 | | |

Now that you know how to find a LCM, we can apply this knowledge to adding and subtracting fractions.

Least Common Denominator (LCD)

To find the least common denominator of common fractions: **find the least common multiple of the denominators .**

Example A: What is the least common denominator of $\frac{1}{2}$ and $\frac{3}{4}$?

The denominators are 2 and 4.

The **least common multiple** of 2 and 4 is **4**.

So the **least common denominator** (LCD) for $\frac{1}{2}$ and $\frac{3}{4}$ is **4**.

Example B: What is the LCD of $\frac{3}{4}$ and $\frac{2}{3}$?

The denominators are 4 and 3.

The **least common multiple** of 4 and 3 is **12**.

So the **least common denominator** for $\frac{3}{4}$ and $\frac{2}{3}$ is **12**.

Exercise Eleven

Find the least common denominator for these pairs of fractions.

| | Fractions | Denominators | Least Common Denominator |
|----|---------------------------------|--------------|--------------------------|
| a) | $\frac{5}{8}$ $\frac{2}{3}$ | 8 3 | 24 |
| b) | $\frac{1}{5}$ $\frac{1}{10}$ | | |
| c) | $\frac{1}{3}$ $\frac{3}{4}$ | | |
| d) | $\frac{1}{8}$ $\frac{3}{4}$ | | |
| e) | $\frac{2}{3}$ $\frac{1}{5}$ | | |
| f) | $\frac{1}{3}$ $\frac{1}{6}$ | | |
| g) | $\frac{5}{8}$ $\frac{1}{16}$ | | |
| h) | $\frac{1}{4}$ $\frac{5}{6}$ | | |

Answers to Exercise Eleven (only least common denominator is given)

b) 10

c) 12

d) 8

e) 15

f) 6

g) 16

h) 12

You know how to find the least common denominator (LCD). The next step is to make **equivalent fractions** using the LCD

Step 1 Find the least common denominator

$$\begin{array}{r} \frac{3}{4} \\ + \frac{1}{3} \\ \hline \end{array} \quad \text{LCD of 4 and 3 is 12.}$$

Step 2 Write an = sign after each fraction, followed by the common denominator.

$$\begin{array}{r} \frac{3}{4} = \frac{?}{12} \\ + \frac{1}{3} = \frac{?}{12} \\ \hline \end{array}$$

Step 3 Rename the fractions as equivalent fractions with the L.C.D.

$$\frac{3}{4} = \frac{?}{12} \quad \text{4 times **what** = 12?"}$$

$$4 \times \mathbf{3} = 12$$

If the denominator was multiplied by 3, the numerator must be multiplied by 3.

$$\frac{3}{4} \left(\frac{3}{3} \right) = \frac{9}{12}$$

Now rename the other fraction.

$$\frac{1}{3} = \frac{?}{12} \quad \text{3 times **what** = 12?}$$

$$3 \times \mathbf{4} = 12$$

If this denominator was multiplied by 4, this numerator must be multiplied by 4.

$$\frac{1}{3} \left(\frac{4}{4} \right) = \frac{4}{12}$$

Step 4 The question now looks like this and can be added.

$$\begin{array}{r} \frac{3}{4} = \frac{9}{12} \\ + \frac{1}{3} = \frac{4}{12} \\ \hline \frac{13}{12} = 1\frac{1}{12} \end{array}$$

Example A: $\frac{1}{4} + \frac{3}{8} = \square$

Step 1 and 2 Find the least common denominator.

$$\begin{array}{r} \frac{1}{4} = \frac{?}{8} \\ + \frac{3}{8} = \frac{?}{8} \\ \hline \end{array}$$

Step 3 Rename as equivalent fractions.

$$\begin{array}{r} \frac{1}{4} \left(\frac{\times 2}{\times 2} \right) = \frac{2}{8} \\ + \frac{3}{8} \left(\frac{\times 1}{\times 1} \right) = \frac{3}{8} \\ \hline \end{array}$$

Step 4 Add and simplify the answer.

$$\begin{array}{r} \frac{1}{4} \left(\frac{\times 2}{\times 2} \right) = \frac{2}{8} \\ + \frac{3}{8} \left(\frac{\times 1}{\times 1} \right) = \frac{3}{8} \\ \hline \frac{5}{8} \end{array}$$

Exercise Twelve

Add these common fractions. Express the answer in lowest terms.

a)

$$\begin{array}{r} \frac{1}{2} \left(\frac{\times 4}{\times 4} \right) = \frac{4}{8} \\ + \frac{3}{8} \left(\frac{\times 1}{\times 1} \right) = \frac{3}{8} \\ \hline \frac{7}{8} \end{array}$$

b)

$$\begin{array}{r} \frac{1}{4} \left(\frac{\times 2}{\times 2} \right) = \frac{2}{8} \\ + \frac{3}{8} \left(\frac{\times 1}{\times 1} \right) = \frac{3}{8} \\ \hline \frac{5}{8} \end{array}$$

c)

$$\begin{array}{r} \frac{1}{5} \\ + \frac{1}{10} \\ \hline \end{array}$$

d)

$$\begin{array}{r} \frac{5}{16} \\ + \frac{1}{4} \\ \hline \end{array}$$

e)

$$\begin{array}{r} \frac{1}{3} \\ + \frac{7}{12} \\ \hline \end{array}$$

f)

$$\begin{array}{r} \frac{1}{2} \\ + \frac{5}{8} \\ \hline \end{array}$$

g)

$$\begin{array}{r} \frac{2}{3} \\ + \frac{1}{6} \\ \hline \end{array}$$

h)

$$\begin{array}{r} \frac{1}{4} \\ + \frac{5}{8} \\ \hline \end{array}$$

i)

$$\begin{array}{r} \frac{3}{10} \\ + \frac{2}{5} \\ \hline \end{array}$$

j)

$$\begin{array}{r} \frac{1}{2} \\ + \frac{5}{6} \\ \hline \end{array}$$

k)

$$\begin{array}{r} \frac{1}{12} \\ + \frac{1}{4} \\ \hline \end{array}$$

l)

$$\begin{array}{r} \frac{1}{2} \\ + \frac{3}{8} \\ \hline \end{array}$$

m)

$$\begin{array}{r} \frac{1}{2} \\ + \frac{3}{10} \\ \hline \end{array}$$

n)

$$\begin{array}{r} \frac{5}{8} \\ + \frac{3}{4} \\ \hline \end{array}$$

o)

$$\begin{array}{r} \frac{1}{2} \\ + \frac{5}{12} \\ \hline \end{array}$$

p)

$$\begin{array}{r} \frac{1}{6} \\ + \frac{3}{4} \\ \hline \end{array}$$

q)

$$\begin{array}{r} \frac{1}{8} \\ + \frac{1}{5} \\ \hline \end{array}$$

r)

$$\begin{array}{r} \frac{1}{12} \\ + \frac{3}{8} \\ \hline \end{array}$$

s)

$$\begin{array}{r} \frac{3}{8} \\ + \frac{1}{6} \\ \hline \end{array}$$

t)

$$\begin{array}{r} \frac{5}{8} \\ + \frac{1}{5} \\ \hline \end{array}$$

u)

$$\begin{array}{r} \frac{3}{4} \\ + \frac{3}{8} \\ \hline \end{array}$$

v)

$$\begin{array}{r} \frac{1}{10} \\ + \frac{1}{2} \\ \hline \end{array}$$

w)

$$\begin{array}{r} \frac{2}{3} \\ + \frac{7}{8} \\ \hline \end{array}$$

x)

$$\begin{array}{r} \frac{1}{4} \\ + \frac{1}{5} \\ \hline \end{array}$$

Answers to Exercise Twelve

c) $\frac{3}{10}$

d) $\frac{9}{16}$

e) $\frac{11}{12}$

f) $1\frac{1}{8}$

g) $\frac{5}{6}$

h) $\frac{7}{8}$

i) $\frac{7}{10}$

j) $1\frac{1}{3}$

k) $\frac{1}{3}$

l) $\frac{7}{8}$

m) $\frac{4}{5}$

n) $1\frac{3}{8}$

o) $\frac{11}{12}$

p) $\frac{11}{12}$

q) $\frac{13}{40}$

r) $\frac{11}{24}$

s) $\frac{13}{24}$

t) $\frac{33}{40}$

u) $1\frac{1}{8}$

v) $\frac{3}{5}$

w) $1\frac{13}{24}$

x) $\frac{9}{20}$



How did you do? If you are struggling with this **process**, speak to your instructor for help.

Exercise Thirteen

More practice. Do only as many as you think you need.

a)

$$\frac{2}{3} \left(\frac{\times 4}{\times 4} \right) = \frac{8}{12}$$

$$\frac{1}{2} \left(\frac{\times 6}{\times 6} \right) = \frac{6}{12}$$

$$+ \frac{3}{4} \left(\frac{\times 3}{\times 3} \right) = \frac{9}{12}$$

$$\frac{23}{12} = 1\frac{11}{12}$$

b)

$$\frac{5}{24} \left(\frac{\times 1}{\times 1} \right) = \frac{5}{24}$$

$$\frac{1}{3} \left(\frac{\times 8}{\times 8} \right) = \frac{8}{24}$$

$$+ \frac{3}{8} \left(\frac{\times 3}{\times 3} \right) = \frac{9}{24}$$

$$\frac{22}{24} = \frac{11}{12}$$

c)

$$\begin{array}{r} \frac{5}{12} \\ \frac{5}{6} \\ + \frac{3}{4} \\ \hline \end{array}$$

d)

$$\begin{array}{r} \frac{3}{10} \\ \frac{3}{4} \\ + \frac{4}{5} \\ \hline \end{array}$$

e)

$$\begin{array}{r} \frac{1}{2} \\ \frac{2}{5} \\ + \frac{7}{10} \\ \hline \end{array}$$

f)

$$\begin{array}{r} \frac{5}{6} \\ \frac{3}{4} \\ + \frac{1}{3} \\ \hline \end{array}$$

g)

$$\begin{array}{r} \frac{7}{16} \\ + \frac{3}{4} \\ \hline \end{array}$$

h)

$$\begin{array}{r} \frac{4}{5} \\ + \frac{1}{3} \\ \hline \end{array}$$

i)

$$\begin{array}{r} \frac{7}{9} \\ + \frac{2}{5} \\ \hline \end{array}$$

j)

$$\begin{array}{r} \frac{1}{5} \\ + \frac{3}{4} \\ \hline \end{array}$$

k)

$$\begin{array}{r} \frac{1}{9} \\ + \frac{2}{3} \\ \hline \end{array}$$

l)

$$\begin{array}{r} \frac{1}{8} \\ + \frac{1}{4} \\ \hline \end{array}$$

Answers to Exercise Thirteen

c) 2

d) $1\frac{17}{20}$

e) $1\frac{3}{5}$

f) $1\frac{11}{12}$

g) $1\frac{3}{16}$

h) $1\frac{2}{15}$

i) $1\frac{8}{45}$

j) $\frac{19}{20}$

k) $\frac{7}{9}$

l) $\frac{3}{8}$

Addition questions are often written with the fractions side by side instead of one fraction above the other. For example

$$\frac{2}{3} + \frac{5}{8} = \square$$

You may solve as shown in this example, **or** rewrite the question with the fractions one above the other.

$$\frac{2}{3} + \frac{5}{8} = \frac{2}{3} \left(\frac{8}{8} \right) + \frac{5}{8} \left(\frac{3}{3} \right) = \frac{16}{24} + \frac{15}{24} = \frac{31}{24} = 1\frac{7}{24}$$

or

$$\begin{array}{r} \frac{2}{3} \left(\frac{\times 8}{\times 8} \right) = \frac{16}{24} \\ + \frac{5}{8} \left(\frac{\times 3}{\times 3} \right) = \frac{15}{24} \\ \hline \frac{31}{24} = 1\frac{7}{24} \end{array}$$

Exercise Fourteen

Find the sum. Do enough questions that you are confident in your skill.

a) $\frac{1}{2} + \frac{1}{6} =$

$$\frac{1}{2} \left(\frac{\times 3}{\times 3} \right) + \frac{1}{6} =$$

$$\frac{3}{6} + \frac{1}{6} = \frac{4}{6} = \frac{2}{3}$$

b) $\frac{1}{4} + \frac{7}{8} =$

c) $\frac{1}{5} + \frac{3}{5} =$

d) $\frac{1}{12} + \frac{2}{3} =$

e) $\frac{1}{3} + \frac{2}{3} =$

f) $\frac{1}{6} + \frac{3}{8} =$

g) $\frac{1}{4} + \frac{1}{6} =$

h) $\frac{1}{8} + \frac{3}{4} =$

i) $\frac{3}{4} + \frac{1}{2} =$

j) $\frac{1}{3} + \frac{5}{8} =$

k) $\frac{1}{4} + \frac{4}{5} =$

l) $\frac{1}{8} + \frac{3}{16} =$

Answers to Exercise Fourteen

b) $1\frac{1}{8}$

c) $\frac{4}{5}$

d) $\frac{3}{4}$

e) 1

f) $\frac{13}{24}$

g) $\frac{5}{12}$

h) $\frac{7}{8}$

i) $1\frac{1}{4}$

j) $\frac{23}{24}$

k) $1\frac{1}{20}$

l) $\frac{5}{16}$

You already know how to add mixed numbers which have the same (like) denominators.

To add mixed numbers with different denominators, you must,

- Find the least common denominator (L.C.D.) for the fractions.
- Rename the fractions as equivalent fractions using the L.C.D.
- **Be sure to bring the whole number across the equal sign when you rename.**
- Add the fractions.
- Add the whole numbers.
- Simplify the answer.
- Remember that if the sum of the fractions is an improper fraction, you must rename it as a mixed number that is added to the whole number in your answer.

Example A:

$$\begin{array}{r} 3\frac{3}{4} \left(\frac{\times 5}{\times 5} \right) = 3\frac{15}{20} \\ + 6\frac{1}{5} \left(\frac{\times 4}{\times 4} \right) = 6\frac{4}{20} \\ \hline 9\frac{19}{20} \end{array}$$

Example B:

$$\begin{array}{r}
 3\frac{1}{4} \left(\frac{\times 3}{\times 3} \right) = 3\frac{3}{12} \\
 8\frac{2}{3} \left(\frac{\times 4}{\times 4} \right) = 8\frac{8}{12} \\
 + 2\frac{1}{2} \left(\frac{\times 6}{\times 6} \right) = 2\frac{6}{12} \\
 \hline
 \end{array}$$

$$13\frac{17}{12} = 13 + 1\frac{5}{12} = 14\frac{5}{12}$$

$\frac{17}{12}$ is an
improper
fraction:

$$\frac{17}{12} = 1\frac{5}{12}$$

Exercise Fifteen

Add. Express the sums in lowest terms. Pace yourself. Do no more than half of them today and do the rest next class.

a)

$$\begin{array}{r}
 1\frac{3}{8} \left(\frac{\times 1}{\times 1} \right) = 1\frac{3}{8} \\
 + 1\frac{1}{4} \left(\frac{\times 2}{\times 2} \right) = 1\frac{2}{8} \\
 \hline
 2\frac{5}{8}
 \end{array}$$

b)

$$\begin{array}{r}
 3\frac{1}{5} \\
 + 2\frac{3}{10} \\
 \hline
 \end{array}$$

c)

$$\begin{array}{r}
 6\frac{2}{15} \\
 + 1\frac{3}{5} \\
 \hline
 \end{array}$$

d)

$$\begin{array}{r}
 8\frac{1}{4} \\
 + 4\frac{1}{3} \\
 \hline
 \end{array}$$

e)

$$\begin{array}{r} 8\frac{2}{5} \\ + 4\frac{1}{3} \\ \hline \end{array}$$

f)

$$\begin{array}{r} 5\frac{2}{3} \\ + 6\frac{1}{4} \\ \hline \end{array}$$

g)

$$\begin{array}{r} 3\frac{2}{7} \\ + 4\frac{1}{14} \\ \hline \end{array}$$

h)

$$\begin{array}{r} 116\frac{5}{8} \\ + 9\frac{1}{24} \\ \hline \end{array}$$

i)

$$\begin{array}{r} 9\frac{4}{5} \\ + 2\frac{1}{15} \\ \hline \end{array}$$

Answers to Exercise Fifteen

b) $5\frac{1}{2}$

c) $7\frac{11}{15}$

d) $12\frac{7}{12}$

e) $12\frac{11}{15}$

f) $11\frac{11}{12}$

g) $7\frac{5}{14}$

h) $125\frac{2}{3}$

i) $11\frac{13}{15}$

Exercise Sixteen

Add. Express the sums in lowest terms. Save part of this exercise to do as review before the test.

a)

$$\begin{array}{r} 4\frac{1}{2} \left(\begin{array}{l} \times 6 \\ \times 6 \end{array} \right) = 4\frac{6}{12} \\ + 2\frac{1}{3} \left(\begin{array}{l} \times 4 \\ \times 4 \end{array} \right) = 2\frac{4}{12} \\ \hline 6\frac{10}{12} = 6\frac{5}{6} \end{array}$$

b)

$$\begin{array}{r} 3\frac{2}{3} \\ + 1\frac{1}{2} \\ \hline \end{array}$$

c)

$$\begin{array}{r} 6\frac{1}{2} \\ + 4\frac{1}{4} \\ \hline \end{array}$$

d)

$$\begin{array}{r} 2\frac{3}{4} \\ + 1\frac{1}{8} \\ \hline \end{array}$$

e)

$$\begin{array}{r} 2\frac{1}{8} \\ + 4\frac{3}{16} \\ \hline \end{array}$$

f)

$$\begin{array}{r} 9\frac{5}{6} \\ + 2\frac{1}{4} \\ \hline \end{array}$$

g)

$$\begin{array}{r} 5\frac{1}{2} \\ 3\frac{2}{3} \\ + 4\frac{1}{4} \\ \hline \end{array}$$

h)

$$\begin{array}{r} 2\frac{1}{5} \\ 3\frac{2}{3} \\ + 6\frac{3}{5} \\ \hline \end{array}$$

i)

$$\begin{array}{r} 7\frac{2}{3} \\ 4\frac{1}{4} \\ + 2\frac{1}{8} \\ \hline \end{array}$$

j)

$$\begin{array}{r} 3\frac{3}{8} \\ 2\frac{3}{4} \\ + 1\frac{1}{2} \\ \hline \end{array}$$

k)

$$\begin{array}{r} 5\frac{7}{10} \\ 4\frac{1}{5} \\ + 2\frac{3}{5} \\ \hline \end{array}$$

l)

$$\begin{array}{r} 4\frac{3}{4} \\ 2\frac{1}{5} \\ + 4\frac{1}{2} \\ \hline \end{array}$$

Answers to Exercise Sixteen

b) $5\frac{1}{6}$

c) $10\frac{3}{4}$

d) $3\frac{7}{8}$

e) $6\frac{5}{16}$

f) $12\frac{1}{12}$

g) $13\frac{5}{12}$

h) $12\frac{7}{15}$

i) $14\frac{1}{24}$

j) $7\frac{5}{8}$

k) $12\frac{1}{2}$

l) $11\frac{9}{20}$

Problems Using Addition of Common Fractions

Exercise Seventeen

Solve these problems.

- a) The bathroom shelf is crowded with hand lotion bottles, each with a little lotion left inside. Everyone always likes to try the new bottle before the old one is emptied! One bottle is $\frac{1}{3}$ full, another is $\frac{1}{4}$ full, one is only $\frac{1}{8}$ full and one is still $\frac{1}{2}$ full. How much lotion is in the bottles altogether?
- b) Sometimes Joan thinks she will go crazy when she packs the lunches for her family. Little Sarah has decided she only wants $\frac{3}{4}$ of a sandwich, Megan wants $\frac{1}{4}$ of a sandwich, Joan's husband takes $1\frac{1}{2}$ sandwiches, and their son, who does heavy work, takes 3 sandwiches! How many sandwiches does Joan make?
- c) Dave paid the baby-sitter for the week. The sitter worked $3\frac{3}{4}$ hours on Monday, $4\frac{1}{4}$ hours on Tuesday and $6\frac{1}{2}$ hours on Friday. How many hours did the baby-sitter work looking after Dave's children that week?

d) Quite a lot of watermelon was left after the watermelon-eating contest: $1\frac{1}{2}$ watermelons on one table, $2\frac{3}{4}$ of a watermelon on another table and $\frac{5}{8}$ of a watermelon on the third table. The organizers want to know exactly how much was left over so they will not buy so much next year. Calculate the amount of watermelon left over.

e) Jeanette has a novel to read for English. She read $\frac{1}{2}$ of the book on the weekend, only had time to read $\frac{1}{8}$ of the book on Monday and another $\frac{1}{4}$ on Wednesday. How much of the book has she read?

f) Dion walks around this route each day for exercise. How far does he walk each day?

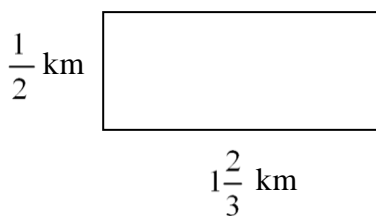

g) How many metres of baseboard are needed for a rectangular room $4\frac{1}{2}$ m by $3\frac{1}{5}$ m?
Deduct 1 m for the doorway.

h) Sana is going to frame a large piece of art with a wooden frame. The art piece is $1\frac{1}{10}$ m by $\frac{3}{5}$ m. How much framing material should she buy?

i) Find the perimeter of the following figure.

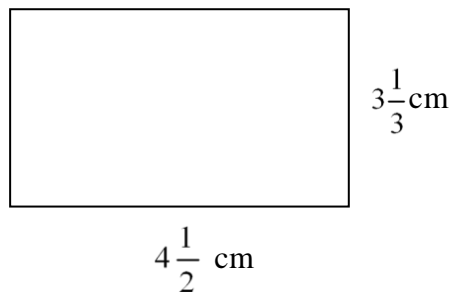

j) Find the perimeter of a cd case if one side is $12\frac{1}{10}$ cm and the other side measures $14\frac{1}{5}$ cm.

k) Find the perimeter of this triangle.

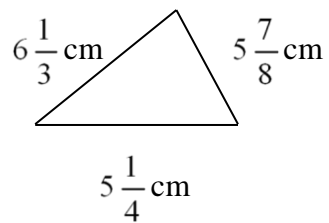

Answers to Exercise Seventeen

- | | | |
|----------------------------------|---------------------------------|--|
| a) $1\frac{5}{24}$ bottles total | b) $5\frac{1}{2}$ sandwiches | c) $14\frac{1}{2}$ hours |
| d) $4\frac{7}{8}$ watermelons | e) $\frac{7}{8}$ of the book | f) He walks $4\frac{1}{3}$ km each day |
| g) $14\frac{2}{5}$ m of material | h) $3\frac{2}{5}$ m of material | i) $15\frac{2}{3}$ cm |
| j) $52\frac{3}{5}$ cm | k) $17\frac{1}{4}$ cm | |

A. Add and express the answers in lowest terms.

6 marks

a)

$$\begin{array}{r} \frac{1}{4} \\ + \frac{3}{4} \\ \hline \end{array}$$

b)

$$\begin{array}{r} 1\frac{3}{5} \\ + 3\frac{4}{5} \\ \hline \end{array}$$

c)

$$\begin{array}{r} \frac{3}{8} \\ + \frac{3}{4} \\ \hline \end{array}$$

d)

$$\begin{array}{r} 2\frac{1}{6} \\ + 3\frac{5}{12} \\ \hline \end{array}$$

e)

$$\begin{array}{r} 6\frac{3}{4} \\ + 2\frac{1}{2} \\ \hline \end{array}$$

f)

$$\begin{array}{r} 6\frac{7}{8} \\ + 9\frac{1}{3} \\ \hline \end{array}$$

B. Problems.**4 marks**

- a) The flight from Vancouver to Castlegar took $1\frac{1}{4}$ hours. The wait in Castlegar was $1\frac{1}{2}$ hours and the flight from there to Calgary was $\frac{3}{4}$ of an hour. How long did it take to make the trip from Vancouver to Calgary?
- b) Dave built $\frac{1}{8}$ of the fence around his house on Monday, $\frac{1}{4}$ of it on Tuesday and another $\frac{1}{4}$ on Wednesday. How much of the fence has he built?
- c) John bought snacks in bulk for the class party. His items weighed $\frac{2}{5}$ kg of chips, $\frac{3}{5}$ kg of peanuts, $\frac{1}{2}$ kg of cheese and $1\frac{1}{4}$ kg of fresh veggies. How much did all his snacks weigh?

- d) Clarence is making a frame for his favourite photo. The frame needs to be $\frac{1}{8}$ m by $\frac{5}{6}$ m. How much material should he buy?

Answers to Topic A Self-Test

A.

- a) 1 b) $5\frac{2}{5}$ c) $1\frac{1}{8}$ d) $5\frac{7}{12}$
e) $9\frac{1}{4}$ f) $16\frac{5}{24}$

B.

- a) $3\frac{1}{2}$ hours b) $\frac{5}{8}$ of the fence c) $2\frac{3}{4}$ kg of food
d) $1\frac{11}{12}$ m of material

Topic B: Subtracting Common Fractions

Good News!

There is only **one new thing** to learn in this topic. Everything else uses skills and knowledge you already have.

Let's look at subtraction:

Example A:

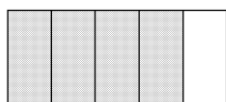

The shaded part ($\frac{4}{5}$) is the amount that you are starting with. Now cross out (pretend you are *taking away*) 3 shaded parts ($\frac{3}{5}$)

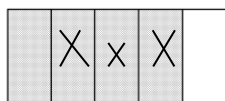

$$\begin{array}{r} \frac{4}{5} \\ - \frac{3}{5} \\ \hline \end{array}$$

You started with a shaded $\frac{4}{5}$ and crossed out a shaded $\frac{3}{5}$.

$$\frac{1}{5}$$

The shaded amount left is $\frac{1}{5}$

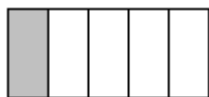

Practice Example B:

Draw a pizza.

- Slice it into 8 equal pieces.
- Draw pieces of pineapple on 5 pieces.
- What fraction of the pizza has pineapple?

$$\frac{5}{8}$$

- Cross out 2 pineapple pieces to show they have been eaten.
- How much of the pineapple pizza is left?

$$\begin{array}{r} \frac{5}{8} \quad (\text{amount you started with}) \\ - \frac{2}{8} \quad (\text{amount eaten, "taken away"}) \\ \hline \frac{3}{8} \end{array}$$

of the pizza is left with pineapple on it.

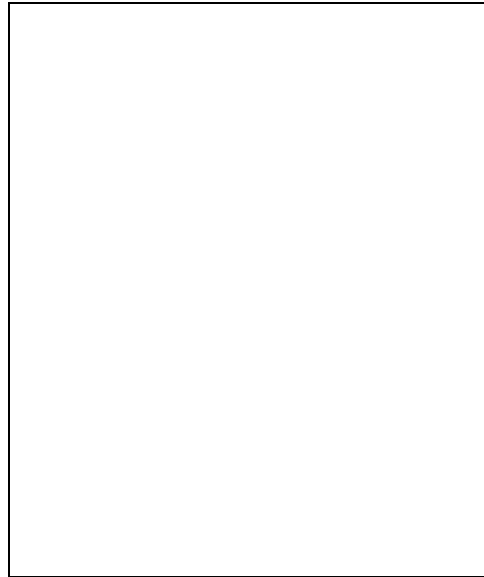

Common fractions must have the same denominator when you subtract one from the other. **Subtract the numerators and keep the same denominators.**

Exercise One

Subtract to find the **difference**. Express the difference in lowest terms.

$$\begin{array}{r} \text{a) } \frac{3}{5} \\ - \frac{1}{5} \\ \hline \frac{2}{5} \end{array}$$

$$\begin{array}{r} \text{b) } \frac{7}{8} \\ - \frac{3}{8} \\ \hline \frac{4}{8} = \frac{1}{2} \end{array}$$

$$\begin{array}{r} \text{c) } \frac{2}{3} \\ - \frac{1}{3} \\ \hline \end{array}$$

$$\begin{array}{r} \text{d) } \frac{11}{16} \\ - \frac{5}{16} \\ \hline \end{array}$$

$$\begin{array}{r} \text{e) } \frac{7}{12} \\ - \frac{4}{12} \\ \hline \end{array}$$

$$\begin{array}{r} \text{f) } \frac{5}{7} \\ - \frac{1}{7} \\ \hline \end{array}$$

$$\begin{array}{r} \text{g) } \frac{5}{9} \\ - \frac{2}{9} \\ \hline \end{array}$$

$$\begin{array}{r} \text{h) } \frac{6}{5} \\ - \frac{4}{5} \\ \hline \end{array}$$

$$\begin{array}{r} \text{i) } \frac{5}{6} \\ - \frac{3}{6} \\ \hline \end{array}$$

$$\text{j) } \frac{6}{7} \\ - \frac{1}{7} \\ \hline$$

$$\text{k) } \frac{3}{4} \\ - \frac{1}{4} \\ \hline$$

$$\text{l) } \frac{3}{2} \\ - \frac{1}{2} \\ \hline$$

Answers to Exercise One

$$\text{c) } \frac{1}{3}$$

$$\text{d) } \frac{3}{8}$$

$$\text{e) } \frac{1}{4}$$

$$\text{f) } \frac{4}{7}$$

$$\text{g) } \frac{1}{3}$$

$$\text{h) } \frac{2}{5}$$

$$\text{i) } \frac{1}{3}$$

$$\text{j) } \frac{5}{7}$$

$$\text{k) } \frac{1}{2}$$

$$\text{l) } \frac{2}{2} = 1$$

You know how to find the **least common denominator (L.C.D.)** and to **rewrite fractions in an equivalent form** using the L.C.D..

You must use those skills when you wish to subtract fractions with different denominators.

Example A: $\frac{4}{5} - \frac{3}{10} = \square$

Denominators are 5 and 10. The least common multiple is 10, so the least common denominator is 10.

$$\frac{4}{5} \left(\frac{\times 2}{\times 2} \right) = \frac{8}{10} \\ - \frac{3}{10} = \frac{3}{10} \\ \hline$$

Write equivalent fractions using the L.C.D.

Subtract the numerators.

$$= \frac{5}{10} \left(\frac{\div 5}{\div 5} \right) = \frac{1}{2}$$

Simplify the answer.

Exercise Two

Subtract and simplify the answers.

$$\begin{array}{r} \text{a) } \frac{5}{6} = \frac{5}{6} \\ -\frac{2(\times 2)}{3(\times 2)} = \frac{4}{6} \\ \hline \frac{1}{6} \end{array}$$

$$\begin{array}{r} \text{b) } \frac{3}{4} = \frac{3}{4} \\ -\frac{1(\times 2)}{2(\times 2)} = \frac{2}{4} \\ \hline \frac{1}{4} \end{array}$$

$$\begin{array}{r} \text{c) } \frac{1}{4} \\ -\frac{1}{12} \\ \hline \end{array}$$

$$\begin{array}{r} \text{d) } \frac{7}{10} \\ -\frac{3}{5} \\ \hline \end{array}$$

$$\begin{array}{r} \text{e) } \frac{3}{4} \\ -\frac{5}{8} \\ \hline \end{array}$$

$$\begin{array}{r} \text{f) } \frac{15}{16} \\ -\frac{5}{8} \\ \hline \end{array}$$

$$\begin{array}{r} \text{g) } \frac{7}{16} \\ -\frac{1}{4} \\ \hline \end{array}$$

$$\begin{array}{r} \text{h) } \frac{2}{5} \\ -\frac{1}{10} \\ \hline \end{array}$$

$$\begin{array}{r} \text{i) } \frac{3}{8} \\ -\frac{1}{4} \\ \hline \end{array}$$

$$\begin{array}{r} \text{j) } \frac{5}{6} \\ -\frac{1}{2} \\ \hline \end{array}$$

$$\begin{array}{r} \text{k) } \frac{2}{3} \\ -\frac{1}{12} \\ \hline \end{array}$$

$$\begin{array}{r} \text{l) } \frac{7}{8} \\ -\frac{1}{2} \\ \hline \end{array}$$

$$\text{m) } \frac{\frac{5}{8}}{-\frac{1}{3}}$$

$$\text{n) } \frac{\frac{2}{3}}{-\frac{1}{8}}$$

$$\text{o) } \frac{\frac{5}{12}}{-\frac{1}{4}}$$

$$\text{p) } \frac{1}{3} - \frac{1}{6} =$$

$$\text{q) } \frac{1}{2} - \frac{1}{6} =$$

$$\text{r) } \frac{1}{4} - \frac{1}{5} =$$

$$\text{s) } \frac{3}{4} - \frac{1}{10} =$$

$$\text{t) } \frac{5}{6} - \frac{5}{8} =$$

$$\text{u) } \frac{1}{8} - \frac{1}{16} =$$

$$\text{v) } \frac{3}{8} - \frac{1}{6} =$$

$$\text{w) } \frac{4}{5} - \frac{1}{2} =$$

Answers to Exercise Two

c) $\frac{1}{6}$

d) $\frac{1}{10}$

e) $\frac{1}{8}$

f) $\frac{5}{16}$

g) $\frac{3}{16}$

h) $\frac{3}{10}$

i) $\frac{1}{8}$

j) $\frac{1}{3}$

k) $\frac{7}{12}$

l) $\frac{3}{8}$

m) $\frac{7}{24}$

n) $\frac{13}{24}$

o) $\frac{1}{6}$

p) $\frac{1}{6}$

q) $\frac{1}{3}$

r) $\frac{1}{20}$

s) $\frac{13}{20}$

t) $\frac{5}{24}$

u) $\frac{1}{16}$

v) $\frac{5}{24}$

w) $\frac{3}{10}$

Subtracting mixed numbers is very similar to adding mixed numbers.

- Find the least common denominator if the fractions do not have the same denominator already.
- Rename the fractions as equivalent fractions using the L.C.D.. **Don't forget to keep whole number with the problem.**
- Subtract the second denominator from the first. Keep the same denominator.
- Subtract the whole numbers.
- Simplify the answer.

Example A:

$$\begin{array}{r}
 4\frac{1}{2} \left(\begin{array}{l} \times 3 \\ \times 3 \end{array} \right) = 4\frac{3}{6} \\
 - 3\frac{1}{6} \\
 \hline
 1\frac{2}{6} = 1\frac{1}{3}
 \end{array}$$

Example B:

$$\begin{array}{r} 12\frac{3}{4}\left(\frac{\times 3}{\times 3}\right) = 12\frac{9}{12} \\ -\frac{2}{3}\left(\frac{\times 4}{\times 4}\right) = \frac{8}{12} \\ \hline 12\frac{1}{12} \end{array}$$

Exercise Three

Work through all these questions carefully.

a)
$$\begin{array}{r} 16\frac{2}{3} = 16\frac{16}{24} \\ -4\frac{3}{8} = 4\frac{9}{24} \\ \hline 12\frac{7}{24} \end{array}$$

b)
$$\begin{array}{r} 9\frac{7}{12} \\ -9\frac{5}{12} \\ \hline \end{array}$$

c)
$$\begin{array}{r} 6\frac{3}{4} \\ -2\frac{1}{3} \\ \hline \end{array}$$

d)
$$\begin{array}{r} 22\frac{5}{6} \\ -18\frac{2}{5} \\ \hline \end{array}$$

e)
$$\begin{array}{r} 3\frac{7}{8} \\ -2\frac{3}{4} \\ \hline \end{array}$$

f)
$$\begin{array}{r} 1\frac{7}{10} \\ -\frac{1}{2} \\ \hline \end{array}$$

$$\begin{array}{r} \text{g)} \quad 8 \frac{7}{12} \\ - 8 \frac{1}{4} \\ \hline \end{array}$$

$$\begin{array}{r} \text{h)} \quad 12 \frac{9}{10} \\ - 10 \frac{1}{5} \\ \hline \end{array}$$

$$\begin{array}{r} \text{i)} \quad 5 \frac{7}{8} \\ - 3 \frac{5}{12} \\ \hline \end{array}$$

$$\begin{array}{r} \text{j)} \quad 9 \frac{1}{4} \\ - 7 \\ \hline \end{array}$$

$$\begin{array}{r} \text{k)} \quad 1 \frac{5}{8} \\ - \frac{1}{3} \\ \hline \end{array}$$

$$\begin{array}{r} \text{l)} \quad 19 \frac{5}{6} \\ - 11 \frac{5}{12} \\ \hline \end{array}$$

Answers to Exercise Three

b) $\frac{1}{6}$

c) $4 \frac{5}{12}$

d) $4 \frac{13}{30}$

e) $1 \frac{1}{8}$

f) $1 \frac{1}{5}$

g) $\frac{1}{3}$

h) $2 \frac{7}{10}$

i) $2 \frac{11}{24}$

j) $2 \frac{1}{4}$

k) $1 \frac{7}{24}$

l) $8 \frac{5}{12}$

Subtracting Mixed Numbers from Whole Numbers

This is the start of a new process! You already have all the skills to do this, but the process is new.

Let's look at some apples.

You have 3 whole apples and you want to give your son 1 apple and your daughter half an apple. How will you do this?



Of course, you will cut one apple in half.



Now you have $2\frac{2}{2}$ apples! And you can easily give away $1\frac{1}{2}$ of them. Cross out $1\frac{1}{2}$ apples in the drawing. How much is left?

Here is the arithmetic for what you just did.

$$\begin{array}{r} 3 = 2\frac{2}{2} \\ -1\frac{1}{2} = 1\frac{1}{2} \\ \hline 1\frac{1}{2} \end{array}$$

Practice Example B:

Here are 6 cans of pop to share among your friends.

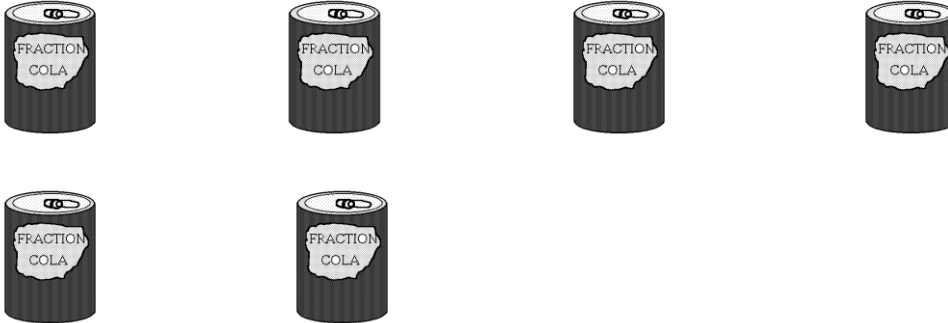

4 people want a whole can, but one gal is on a diet and only wants $\frac{1}{4}$ of a can. How much pop will be left?

What will you do? You will open a can and think of that can as $\frac{4}{4}$.



You have $5\frac{4}{4}$ cans of pop and you can give out 4 whole cans and $\frac{1}{4}$ can of pop. Cross out the 4 whole cans and $\frac{1}{4}$ of a can in the drawing.

How many cans are left?

Here is the arithmetic:

$$\begin{array}{r}
 6 = 5\frac{4}{4} \\
 - 4\frac{1}{4} \\
 \hline
 1\frac{3}{4}
 \end{array}$$

Practice Example C:

Draw five apple pies. Plan to give away $3\frac{2}{3}$ of the pies. How many pies are left?

To do that, cut one pie into thirds. Then cross out 3 whole pies and $\frac{2}{3}$.

Here is the arithmetic:

$$\begin{array}{r} 5 = 4\frac{3}{3} \\ - 3\frac{2}{3} = 3\frac{2}{3} \\ \hline 1\frac{1}{3} \text{ pies left} \end{array}$$

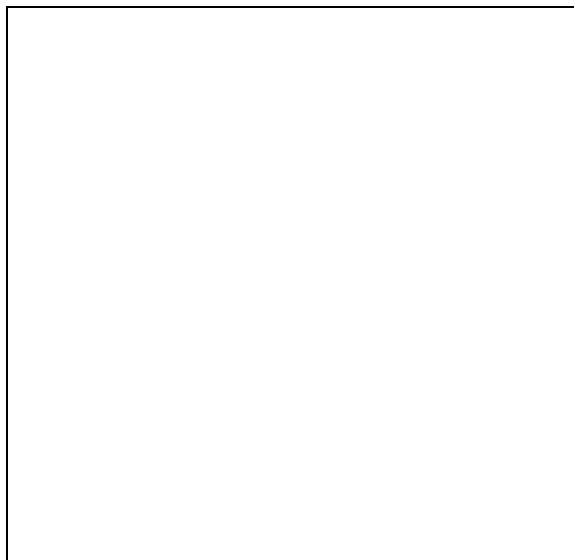

⇒ Remember $1 = \frac{1}{1} = \frac{2}{2} = \frac{3}{3} = \frac{4}{4} = \frac{5}{5} = \frac{6}{6} = \frac{7}{7} = \frac{8}{8} = \frac{9}{9} = \frac{10}{10}$ and so on.

To subtract a mixed number from a whole number

Step 1 "Borrow" **one** from the whole number.

Step 2 Rename the one as an improper fraction with the same denominator as the fraction you are taking away. (Remember to change the whole number to one less.)

Step 3 Subtract the mixed numbers.

Example A: $18 - 12\frac{3}{4} = \square$

$$\begin{array}{r} 17\frac{4}{4} = 17\frac{4}{4} \\ - 12\frac{3}{4} = 12\frac{3}{4} \\ \hline 5\frac{1}{4} \end{array}$$

The one that was borrowed changes to $\frac{4}{4}$

Example B: $1 - \frac{4}{5} = \square$

$$\begin{array}{r} 1 = \frac{5}{5} \\ - \frac{4}{5} = \frac{4}{5} \\ \hline \frac{1}{5} \end{array}$$

Exercise Four

Subtract and express in lowest terms. (Remember to change your whole number to a mixed numeral).

$$\begin{array}{r} \text{a) } 5 = 4\frac{2}{2} \\ -1\frac{1}{2} = 1\frac{1}{2} \\ \hline 3\frac{1}{2} \end{array}$$

$$\begin{array}{r} \text{b) } 9 \\ -4\frac{3}{10} \\ \hline \end{array}$$

$$\begin{array}{r} \text{c) } 12 \\ -11\frac{5}{8} \\ \hline \end{array}$$

$$\begin{array}{r} \text{d) } 25 \\ -20\frac{1}{4} \\ \hline \end{array}$$

$$\begin{array}{r} \text{e) } 3 \\ -2\frac{2}{3} \\ \hline \end{array}$$

$$\begin{array}{r} \text{f) } 8 \\ -\frac{3}{4} \\ \hline \end{array}$$

$$\begin{array}{r} \text{g) } 4 \\ -2\frac{2}{5} \\ \hline \end{array}$$

$$\begin{array}{r} \text{h) } 1 \\ -\frac{1}{2} \\ \hline \end{array}$$

$$\begin{array}{r} \text{i) } 21 \\ -19\frac{2}{4} \\ \hline \end{array}$$

$$\begin{array}{r} \text{j) } 32 \\ -28\frac{1}{2} \\ \hline \end{array}$$

$$\begin{array}{r} \text{k) } 5 \\ -3\frac{1}{3} \\ \hline \end{array}$$

$$\begin{array}{r} \text{l) } 8 \\ -4\frac{4}{9} \\ \hline \end{array}$$

Answers to Exercise Four

b) $4\frac{7}{10}$

c) $\frac{3}{8}$

d) $4\frac{3}{4}$

e) $\frac{1}{3}$

f) $7\frac{1}{4}$

g) $1\frac{3}{5}$

h) $\frac{1}{2}$

i) $1\frac{1}{2}$

j) $3\frac{1}{2}$

k) $1\frac{2}{3}$

l) $3\frac{5}{9}$

Renaming to Subtract Mixed Numbers

Look at the $3\frac{1}{4}$ chocolate bars.



You need to give $2\frac{3}{4}$ chocolate bars to the kids on the soccer team. How will you do this?

You will have to cut up one of the whole chocolate bars into 4 pieces, or $\frac{4}{4}$.



Now you have 2 whole bars, $\frac{4}{4}$ of a bar and $\frac{1}{4}$ of a bar which equals $2\frac{5}{4}$ of a bar. It will be easy to give away (subtract) $2\frac{3}{4}$ bars. Cross out $2\frac{3}{4}$ bars.

How much is left?

Here is the arithmetic: $3\frac{1}{4} - 2\frac{3}{4} = \square$

$$\begin{array}{r}
 3\frac{1}{4} = 2\frac{4}{4} + \frac{1}{4} = 2\frac{5}{4} \\
 - 2\frac{3}{4} \\
 \hline
 \frac{2}{4} = \frac{1}{2} \text{ chocolate bar left}
 \end{array}$$

Practice Example B: Look at the $5\frac{1}{8}$ cherry pies.

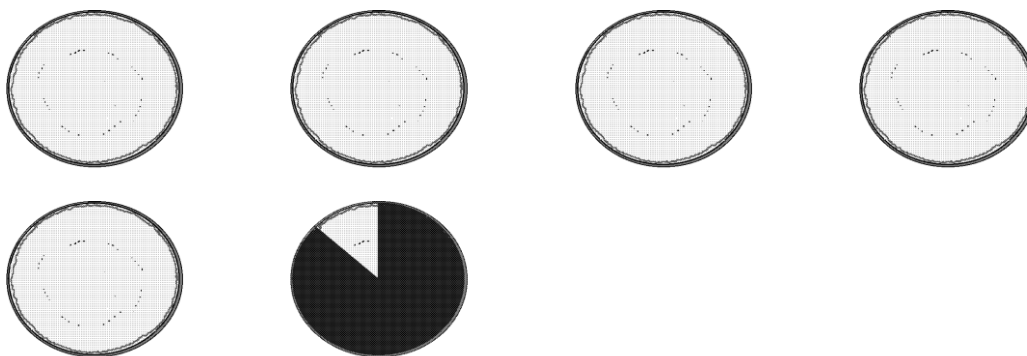

You promised to send $3\frac{5}{8}$ pies to the spring party at the school. What will you do? Cut one of the pies into eighths.

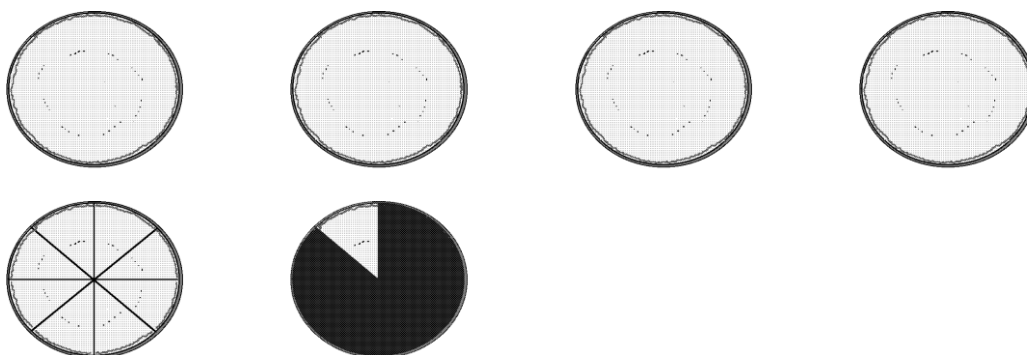

Do that, and then cross out $3\frac{5}{8}$ pies. How much pie is left?

$$\begin{array}{r}
 5\frac{1}{8} = 4\frac{8}{8} + \frac{1}{8} = 4\frac{9}{8} \\
 - 3\frac{5}{8} \\
 \hline
 1\frac{4}{8} = 1\frac{1}{2} \text{ pies}
 \end{array}$$

Renaming a mixed number so you can subtract

Step 1 Check to see if renaming is needed. That is, check that the fraction in the mixed number you are starting with is **less** than the fraction you want to take away.

$$4\frac{1}{3} - 2\frac{2}{3} = \square \left(\frac{1}{3} \text{ is less than } \frac{2}{3} \right)$$

Step 2 "Borrow" **one** from the whole number (**Remember to change the whole number to 1 less.**)

Step 3 **Rename** the "borrowed" **one** as an improper fraction with the same denominator as the other fractions.

$$4\frac{1}{3} = 3\overset{\textcircled{3}}{\frac{3}{3}} + \frac{1}{3}$$

This becomes the 1 that you borrowed from the four

Step 4 Add the renamed one to the fraction that is part of the same mixed number.

$$3\frac{3}{3} + \frac{1}{3} = 3\frac{4}{3}$$

Step 5 Subtract as usual, expressing your answer in lowest terms.

$$\begin{array}{r} 4\frac{1}{3} = 3\frac{4}{3} \\ - 2\frac{2}{3} = 2\frac{2}{3} \\ \hline 1\frac{2}{3} \end{array}$$

Example A $5\frac{2}{5} - 2\frac{4}{5} = \square$

Step 1 $\frac{2}{5}$ is less than $\frac{4}{5}$, so renaming is required.

Step 2 and 3 Borrow one.

$$5\frac{2}{5} = 4\frac{5}{5} + \frac{2}{5}$$

Step 4 and 5

$$\begin{array}{r} 5\frac{2}{5} = 4\frac{5}{5} + \frac{2}{5} = 4\frac{7}{5} \\ - 2\frac{4}{5} = \qquad \qquad \qquad 2\frac{4}{5} \\ \hline 2\frac{3}{5} \end{array}$$

Example B: $1\frac{2}{4} - \frac{3}{4} = \square$

Step 1 $\frac{2}{4}$ is less than $\frac{3}{4}$, so we need to rename to subtract.

Step 2, 3, 4 and 5

$$\begin{array}{r} 1\frac{2}{4} = \frac{4}{4} + \frac{2}{4} = \frac{6}{4} \\ - \frac{3}{4} = \frac{3}{4} \\ \hline \frac{3}{4} \end{array}$$

Exercise Five

Subtract. Be sure the answers are in lowest terms.

a) $20\frac{1}{4} = 19\frac{5}{4}$
 $-10\frac{3}{4} = 10\frac{3}{4}$
 $\hline 9\frac{2}{4} = 9\frac{1}{2}$

b) $3\frac{1}{3}$
 $-1\frac{2}{3}$
 \hline

c) $56\frac{2}{5}$
 $-20\frac{4}{5}$
 \hline

d) $8\frac{1}{3}$
 $-4\frac{2}{3}$
 \hline

e) $4\frac{1}{5}$
 $-2\frac{3}{5}$
 \hline

f) $5\frac{2}{7}$
 $-1\frac{3}{7}$
 \hline

g) $12\frac{5}{9}$
 $-10\frac{7}{9}$
 \hline

h) $2\frac{3}{11}$
 $-1\frac{5}{11}$
 \hline

i) $5\frac{1}{6}$
 $-\frac{5}{6}$
 \hline

$$\begin{array}{r} 9\frac{3}{5} \\ - \frac{4}{5} \\ \hline \end{array}$$

$$\text{k) } \begin{array}{r} 4\frac{1}{4} \\ - 1\frac{3}{4} \\ \hline \end{array}$$

$$\text{l) } \begin{array}{r} 15\frac{3}{8} \\ - 14\frac{7}{8} \\ \hline \end{array}$$

Answers to Exercise Five

$$\text{b) } 1\frac{2}{3}$$

$$\text{c) } 35\frac{3}{4}$$

$$\text{d) } 3\frac{2}{3}$$

$$\text{e) } 1\frac{3}{5}$$

$$\text{f) } 3\frac{6}{7}$$

$$\text{g) } 1\frac{7}{9}$$

$$\text{h) } \frac{9}{11}$$

$$\text{i) } 4\frac{1}{3}$$

$$\text{j) } 8\frac{4}{5}$$

$$\text{k) } 2\frac{1}{2}$$

$$\text{l) } \frac{1}{2}$$

Here is the last step for subtraction of fractions.

Mixed numbers to be subtracted often do not have the same denominators—they are **unlike fractions**.

You must

- Write equivalent fractions using the L.C.D.
- Decide if you need to "borrow" or rename before you subtract.
- Subtract and simplify the answer.

$$\text{Example A: } 4\frac{1}{3} - 2\frac{5}{6} = \square$$

$$\begin{array}{r} 4\frac{1}{3} = 4\frac{2}{6} = 3\frac{6}{6} + \frac{2}{6} = 3\frac{8}{6} \\ - 2\frac{5}{6} \\ \hline 1\frac{3}{6} = 1\frac{1}{2} \end{array}$$

Example B: $9\frac{1}{10} - 4\frac{1}{4} = \square$

$$\begin{array}{r} 9\frac{1}{10} = 9\frac{2}{20} = 8\frac{20}{20} + \frac{2}{20} = 8\frac{22}{20} \\ -4\frac{1}{4} = 4\frac{5}{20} \\ \hline 4\frac{17}{20} \end{array}$$

Exercise Six

Subtract. Be sure the answers are in lowest terms.

a)
$$\begin{array}{r} 9\frac{3}{8} = 9\frac{3}{8} = 8\frac{11}{8} \\ -7\frac{1}{2} = 7\frac{4}{8} = 7\frac{4}{8} \\ \hline 1\frac{7}{8} \end{array}$$

b)
$$\begin{array}{r} 7\frac{1}{16} \\ -4\frac{1}{8} \\ \hline \end{array}$$

c)
$$\begin{array}{r} 15\frac{1}{6} \\ -12\frac{7}{8} \\ \hline \end{array}$$

d)
$$\begin{array}{r} 20\frac{2}{6} \\ -16\frac{2}{3} \\ \hline \end{array}$$

e)
$$\begin{array}{r} 6\frac{3}{5} \\ -4\frac{1}{4} \\ \hline \end{array}$$

f)
$$\begin{array}{r} 9\frac{1}{4} \\ -7\frac{3}{8} \\ \hline \end{array}$$

$$\begin{array}{r} \text{g)} \quad 15\frac{1}{2} \\ -12\frac{3}{4} \\ \hline \end{array}$$

$$\begin{array}{r} \text{h)} \quad 19\frac{1}{8} \\ -14\frac{1}{2} \\ \hline \end{array}$$

$$\begin{array}{r} \text{i)} \quad 8\frac{3}{10} \\ -5\frac{1}{2} \\ \hline \end{array}$$

$$\begin{array}{r} \text{j)} \quad 4\frac{5}{12} \\ -3\frac{3}{4} \\ \hline \end{array}$$

$$\begin{array}{r} \text{k)} \quad 5\frac{1}{3} \\ -2\frac{1}{2} \\ \hline \end{array}$$

$$\begin{array}{r} \text{l)} \quad 18\frac{1}{6} \\ -12\frac{2}{3} \\ \hline \end{array}$$

Answers to Exercise Six

$$\text{b)} \quad 2\frac{15}{16}$$

$$\text{c)} \quad 2\frac{7}{24}$$

$$\text{d)} \quad 3\frac{2}{3}$$

$$\text{e)} \quad 2\frac{7}{20}$$

$$\text{f)} \quad 1\frac{7}{8}$$

$$\text{g)} \quad 2\frac{3}{4}$$

$$\text{h)} \quad 4\frac{5}{8}$$

$$\text{i)} \quad 2\frac{4}{5}$$

$$\text{j)} \quad \frac{2}{3}$$

$$\text{k)} \quad 2\frac{5}{6}$$

$$\text{l)} \quad 5\frac{1}{2}$$

Exercise Seven

A Subtraction Review

$$\begin{array}{r} \text{a) } \frac{5}{8} \\ -\frac{1}{4} \\ \hline \end{array}$$

$$\begin{array}{r} \text{b) } 8\frac{3}{4} \\ -4\frac{1}{3} \\ \hline \end{array}$$

$$\begin{array}{r} \text{c) } 13\frac{1}{3} \\ -12\frac{5}{6} \\ \hline \end{array}$$

$$\begin{array}{r} \text{d) } 7\frac{1}{3} \\ -4\frac{5}{6} \\ \hline \end{array}$$

$$\begin{array}{r} \text{e) } 8\frac{3}{10} \\ -\frac{9}{10} \\ \hline \end{array}$$

$$\begin{array}{r} \text{f) } 3\frac{1}{4} \\ -\frac{5}{6} \\ \hline \end{array}$$

$$\begin{array}{r} \text{g) } 9\frac{1}{5} \\ -6\frac{1}{3} \\ \hline \end{array}$$

$$\begin{array}{r} \text{h) } 7 \\ -1\frac{7}{8} \\ \hline \end{array}$$

$$\begin{array}{r} \text{i) } 9\frac{1}{4} \\ -5\frac{2}{3} \\ \hline \end{array}$$

$$\begin{array}{r} \text{j) } 6\frac{4}{5} \\ -\frac{1}{2} \\ \hline \end{array}$$

$$\begin{array}{r} \text{k) } 19\frac{2}{3} \\ -18 \\ \hline \end{array}$$

$$\begin{array}{r} \text{l) } \frac{5}{8} \\ -\frac{1}{2} \\ \hline \end{array}$$

Answers to Exercise Seven

a) $\frac{3}{8}$

b) $4\frac{5}{12}$

c) $\frac{1}{2}$

d) $2\frac{1}{2}$

e) $7\frac{2}{5}$

f) $2\frac{5}{12}$

g) $2\frac{13}{15}$

h) $5\frac{1}{8}$

i) $3\frac{7}{12}$

j) $6\frac{3}{10}$

k) $1\frac{2}{3}$

l) $\frac{1}{8}$

Problems Using Subtraction of Common Fractions

Subtraction problems may ask you to

- find the difference between two amounts.
 - "how much more is..."
 - "how much less is..."
- take away, give away, or lose.
- decide how much is left or how much remains.

Read over the subtraction problems that you did in Unit Two with decimals. The wording and problem situations will be similar.

Drawing a sketch and estimating the answer using whole numbers may also be helpful.

Exercise Eight

Solve these problems.

- a) The New Earth Diaper Company stocks went from $5\frac{7}{8}$ to $7\frac{3}{8}$ this week.
- b) How much did the stocks increase in value?

- b) Jean is knitting an afghan which will be made from 5 long pieces. She has finished $3\frac{2}{3}$ of the pieces. How many pieces does she still have to knit?

- c) Dave said he worked in the garden for $6\frac{1}{4}$ hours, but his wife saw him snoozing under a tree for $1\frac{1}{2}$ hours! How long did Dave really work?
- d) Maureen left $\frac{2}{3}$ of a big lasagne casserole in the fridge hoping it would be enough for a quick dinner that night. But alas, when she got home, only $\frac{1}{4}$ of the big lasagne casserole remained. How much of the lasagne was eaten while she was out?
- e) In the first half of 1992 the Bank of Canada Prime Rate dropped steadily. It started the year at $8\frac{1}{2}\%$ and was at a low $6\frac{3}{4}\%$ in July. How many percentage points did the prime rate drop? (Note: treat the % just like a unit in this problem.)

f) Mark is $1\frac{3}{4}$ meters tall. His partner is $1\frac{1}{3}$ meters tall. How much taller is Mark than his partner?

g) A teenager can drink $3\frac{3}{4}$ litres of milk each day. If this teenager drinks $2\frac{1}{2}$ litres by lunch, how much more milk will he drink in the day?

h) Joan bought $13\frac{1}{2}$ metres to do her sewing project. She has used $8\frac{1}{5}$ metres so far. How much material does she have left?

Answers to Exercise Eight

a) $1\frac{4}{8}$ or \$1.50

b) $1\frac{1}{3}$ pieces

c) $4\frac{3}{4}$ hours

d) $\frac{5}{12}$ of the lasagna

e) $1\frac{3}{4}$ percentage points

f) $\frac{5}{12}$ metres taller

g) $1\frac{1}{4}$ litres left to drink

h) $5\frac{3}{10}$ meters left

Topic B Self-Test

Mark /15 Aim 12/15

A. Subtract these fractions. Simplify the answers when necessary.

15 marks

a)
$$\begin{array}{r} \frac{7}{8} \\ - \frac{1}{8} \\ \hline \end{array}$$

b)
$$\begin{array}{r} \frac{11}{15} \\ - \frac{4}{15} \\ \hline \end{array}$$

c)
$$\begin{array}{r} \frac{7}{8} \\ - \frac{3}{16} \\ \hline \end{array}$$

d)
$$\begin{array}{r} \frac{2}{3} \\ - \frac{1}{6} \\ \hline \end{array}$$

e)
$$\begin{array}{r} \frac{4}{7} \\ - \frac{1}{14} \\ \hline \end{array}$$

f)
$$\begin{array}{r} \frac{4}{5} \\ - \frac{3}{8} \\ \hline \end{array}$$

g)
$$\begin{array}{r} 4 \\ - 2\frac{1}{2} \\ \hline \end{array}$$

h)
$$\begin{array}{r} 5 \\ - 4\frac{7}{8} \\ \hline \end{array}$$

i)
$$\begin{array}{r} 10\frac{3}{5} \\ - 3\frac{3}{10} \\ \hline \end{array}$$

j)
$$\begin{array}{r} 7\frac{1}{5} \\ - 3\frac{4}{5} \\ \hline \end{array}$$

k)
$$\begin{array}{r} 12\frac{1}{8} \\ - 11 \\ \hline \end{array}$$

l)
$$\begin{array}{r} 9\frac{1}{5} \\ - \frac{1}{4} \\ \hline \end{array}$$

m)
$$\begin{array}{r} 5\frac{1}{4} \\ - 1\frac{2}{3} \\ \hline \end{array}$$

n)
$$\begin{array}{r} 10\frac{1}{2} \\ - 2\frac{2}{5} \\ \hline \end{array}$$

o)
$$\begin{array}{r} 6\frac{2}{3} \\ - 4\frac{3}{8} \\ \hline \end{array}$$

Answers to Topic B Self-Test

Part A

a) $\frac{3}{4}$

b) $\frac{7}{15}$

c) $\frac{11}{16}$

d) $\frac{1}{2}$

e) $\frac{1}{2}$

f) $\frac{17}{40}$

g) $1\frac{1}{2}$

h) $\frac{1}{8}$

i) $7\frac{3}{10}$

j) $3\frac{2}{5}$

k) $1\frac{1}{8}$

l) $8\frac{19}{20}$

m) $3\frac{7}{12}$

n) $8\frac{1}{10}$

o) $2\frac{7}{24}$

Topic C: Problems Using Common Fractions

Review again the **five steps for problem solving**.

- Step 1** **Read, find the question.**
- Step 2** Get the **necessary information** from the problem.
- Step 3** **Decide** on the **arithmetic operation**.
- Step 4** **Estimate** the answer, using rounded numbers. **Does the answer to the problem seem sensible?**
- Step 5** **Solve** the problem using the **actual numbers**. Check. Is the answer close to the estimate?

Fraction problems with mixed numbers are easily estimated by rounding the fraction to the nearest whole number.

If the problem uses **proper fractions** it is **harder to estimate the answer** using a rounded number because proper fractions will round off to either 0 or 1, which isn't too useful. However, to figure out the operation to use (Step 3), it sometimes helps to **substitute whole numbers** for the proper fraction; this may help you to make sense of the problem. Drawing a sketch might also be helpful.

Exercise One

- a) The following recipe for **Macaroni and Cheese** is very tasty. It feeds six people. Look at the recipe and then complete the chart according to these questions.
 - i) You want to make enough macaroni and cheese for 9 people. That is $\frac{9}{6}$ ($1\frac{1}{2}$) of the recipe. Figure out all the quantities.
 - ii) Figure out the quantities for $\frac{1}{2}$ the recipe, so it is the right amount for 3 people.

Tasty Macaroni and Cheese

| Ingredients for 6 people | Quantities for 9 people ($1\frac{1}{2}$ x) | Quantities for 3 people ($\frac{1}{2}$ x) |
|--|---|--|
| $1\frac{3}{4}$ cup elbow macaroni | $2\frac{5}{8}$ cups | $\frac{7}{8}$ cup |
| $\frac{3}{4}$ cup chopped onion | | |
| $\frac{1}{2}$ cup chopped green pepper | | |
| 10 sliced mushrooms | | |
| 3 tbsp. butter or margarine | | |
| $1\frac{1}{2}$ tbsp. flour | | |
| 1 tsp. dry mustard | | |
| $\frac{3}{4}$ tsp. salt | | |
| $\frac{1}{4}$ tsp. oregano | | |
| $2\frac{1}{2}$ cups milk | | |
| $2\frac{1}{2}$ cups shredded cheddar cheese | | |
| $\frac{1}{2}$ cup fine dry breadcrumbs | | |

Cook and drain macaroni. Turn into a casserole dish. Saute onion, green pepper, and mushrooms in butter until tender. Blend in flour, mustard, salt, and oregano. Gradually stir in milk and cook over medium heat until thick. Add four-fifths of the cheese and stir until melted. Pour over macaroni and stir gently. Combine remaining cheese and breadcrumbs and sprinkle on top. Bake at 350° F for 30 to 40 minutes. Serve with a green vegetable or salad.

b) Jack spent his school day this way: $1\frac{1}{4}$ hours on English, $1\frac{3}{4}$ hours on math, $\frac{1}{2}$ hour on science and 2 hours on lunch and coffee breaks. How long was his school day?

c) The canoe trip usually takes $4\frac{1}{4}$ hours for the 34 kilometre trip. What is the average time per kilometre?

d) The "Walkyerbunsoff" Club members walk $4\frac{3}{4}$ kilometres around the shopping mall six mornings a week.

i) How far do they walk each week?

ii) How far do they walk in one year if they keep the same schedule?
(52 weeks = 1 year)

- e) The test has 30 multiple choice questions to be completed in $\frac{3}{4}$ of an hour. How much time can be spent on each question? (It might be easier to work with minutes. 1 hour = 60 minutes, so $\frac{3}{4}$ of an hour = ? minutes.)
- f) The gas tank was filled before the family left Radium Hot Springs. When they pulled into Salmon Arm that afternoon, the gas gauge showed they had used $\frac{5}{8}$ of the gas.
- i) What fraction of the gas was left?
- ii) The full gas tank holds 54 litres. How many litres of gas did they use in the trip from Radium Hot Springs to Salmon Arm?
- g) About $\frac{2}{5}$ of the population of our city has an Italian background. The population is 6500. How many people in our city have an Italian background?

- h) The four children carefully planted 3 rows of corn together and promised to share the work and the corn. Only $2\frac{1}{4}$ rows of corn came up. How much of a row does each child need to look after?
- i) Gail was supposed to babysit for $2\frac{3}{4}$ hours, but she didn't feel well so her sister Debbie said she would come for $\frac{1}{2}$ of the time. How long did each girl babysit?
- j) The WP stocks closed at $6\frac{1}{8}$ on Monday. On Tuesday they fell $\frac{1}{4}$. What was the value of the stocks at closing on Tuesday?
- k) The same WP stocks had a good day on Wednesday. They rose $\frac{3}{4}$ from the Tuesday closing price (see question j). What was the value of the WP stocks at closing on Wednesday?

- l) Victor and his family heat their house with wood. Last year they cut and hauled $12\frac{1}{2}$ cords of wood from the bush. At $\frac{1}{2}$ cord per pick-up truck load, how many trips did they have to make with their one truck?
- m) Bankers suggest that when you buy a home, the cost of the house should be no more than $2\frac{1}{2}$ times your annual income. Between them, John and Pam Miller have a gross annual income of \$68 000. About how much would the bankers say they should spend on a house?
- n) The loaded logging trucks cover 38.5 km from the logging site down the steep logging roads to the highway in $1\frac{1}{4}$ hours. What is their average speed in kilometres per hour?

Answers to Exercise One

a) Tasty Macaroni and Cheese

| Ingredients for 6 people | Quantities for 9 people ($1\frac{1}{2}\times$) | Quantities for 3 people ($\frac{1}{2}\times$) |
|---|--|---|
| $1\frac{3}{4}$ cup elbow macaroni | $2\frac{5}{8}$ cups | $\frac{7}{8}$ cup |
| $\frac{3}{4}$ cup chopped onion | $1\frac{1}{8}$ cup | $\frac{3}{8}$ cup |
| $\frac{1}{2}$ cup chopped green pepper | $\frac{3}{4}$ cup | $\frac{1}{4}$ cup |
| 10 sliced mushrooms | 15 | 5 |
| 3 tbsp. butter or margarine | $4\frac{1}{2}$ tbsp. | $1\frac{1}{2}$ tbsp. |
| $1\frac{1}{2}$ tbsp. flour | $2\frac{1}{4}$ tbsp. | $\frac{3}{4}$ tbsp. |
| 1 tsp. dry mustard | $1\frac{1}{2}$ tsp. | $\frac{1}{2}$ tsp. |
| $\frac{3}{4}$ tsp. salt | $1\frac{1}{8}$ tsp. | $\frac{3}{8}$ tsp. |
| $\frac{1}{4}$ tsp. oregano | $\frac{3}{8}$ tsp. | $\frac{1}{8}$ tsp. |
| $2\frac{1}{2}$ cups milk | $3\frac{3}{4}$ cups | $1\frac{1}{4}$ cups |
| $2\frac{1}{2}$ cups shredded cheddar cheese | $3\frac{3}{4}$ cups | $1\frac{1}{4}$ cups |
| $\frac{1}{2}$ cup fine dry breadcrumbs | $\frac{3}{4}$ cup | $\frac{1}{4}$ cup |

- b) $5\frac{1}{2}$ hours c) $\frac{1}{8}$ hours/km or $7\frac{1}{2}$ min/km d) i) $28\frac{1}{2}$ km ii) 1482 km
- e) $1\frac{1}{2}$ minutes/question f) i) $\frac{3}{8}$ tank ii) $33\frac{3}{4}$ L g) 2 600 people
- h) $\frac{9}{16}$ of a row i) $1\frac{3}{8}$ hours j) $5\frac{7}{8}$
- k) $6\frac{5}{8}$ l) 25 trips m) \$170 000
- n) $30\frac{2}{5}$ km/h

Unit 4 Review

1. Add these common fractions, make sure to reduce your answer to the lowest terms.

a) $\frac{1}{3} + \frac{1}{3} =$

b) $\frac{3}{7} + \frac{2}{7} =$

c) $\frac{4}{5} + \frac{1}{5} =$

d) $\frac{3}{8} + \frac{1}{8} =$

e) $\frac{4}{8} + \frac{2}{8} =$

f) $\frac{1}{12} + \frac{3}{12} =$

g) $\frac{3}{7} + \frac{5}{7} =$

h) $\frac{7}{21} + \frac{7}{21} =$

2. Add these common fractions, make sure to reduce your answer.

a) $\frac{1}{3} + \frac{3}{6} =$

b) $\frac{1}{2} + \frac{2}{5} =$

c) $\frac{1}{4} + \frac{1}{3} =$

d) $\frac{3}{5} + \frac{3}{4} =$

e) $\frac{3}{7} + \frac{6}{8} =$

f) $\frac{1}{2} + \frac{13}{16} =$

$$\text{g) } \frac{1}{8} + \frac{1}{3} =$$

$$\text{h) } \frac{3}{8} + \frac{4}{9} =$$

$$\text{i) } \frac{4}{7} + \frac{8}{9} =$$

$$\text{j) } \frac{1}{30} + \frac{3}{4} =$$

3. Add. Express the sum in lowest terms

$$\text{a) } 6\frac{3}{5} + 2\frac{3}{7} =$$

$$\text{b) } 3\frac{1}{4} + 4\frac{1}{2} =$$

$$\text{c) } 3\frac{3}{8} + 4\frac{1}{4} =$$

$$\text{d) } 8\frac{1}{5} + 1\frac{2}{7} =$$

$$\text{e) } 1\frac{14}{15} + 3\frac{1}{3} =$$

$$\text{f) } 4\frac{2}{3} + 1\frac{1}{4} =$$

$$\text{g) } 12\frac{1}{2} + 1\frac{1}{3} =$$

$$\text{h) } 9\frac{2}{5} + 1\frac{7}{10} =$$

$$\text{i) } 9\frac{4}{5} + 3\frac{1}{7} =$$

$$\text{j) } 2\frac{1}{5} + 7\frac{4}{15} =$$

4. Subtract. Express your answers in lowest terms.

$$\text{a) } \begin{array}{r} \frac{2}{5} \\ - \frac{1}{5} \\ \hline \end{array}$$

$$\text{b) } \begin{array}{r} \frac{5}{8} \\ - \frac{1}{8} \\ \hline \end{array}$$

$$\text{c) } \begin{array}{r} \frac{2}{3} \\ - \frac{1}{3} \\ \hline \end{array}$$

$$\text{d) } \begin{array}{r} \frac{5}{12} \\ - \frac{3}{12} \\ \hline \end{array}$$

$$\text{e) } \begin{array}{r} \frac{17}{22} \\ - \frac{6}{22} \\ \hline \end{array}$$

$$\text{f) } \begin{array}{r} \frac{8}{9} \\ - \frac{5}{9} \\ \hline \end{array}$$

5. Subtract and simplify the answer.

$$\text{a) } \begin{array}{r} \frac{5}{6} \\ - \frac{2}{3} \\ \hline \end{array}$$

$$\text{b) } \begin{array}{r} \frac{3}{4} \\ - \frac{1}{2} \\ \hline \end{array}$$

$$\begin{array}{r} \text{c) } \frac{3}{4} \\ - \frac{1}{12} \\ \hline \end{array}$$

$$\begin{array}{r} \text{d) } \frac{9}{10} \\ - \frac{4}{5} \\ \hline \end{array}$$

$$\begin{array}{r} \text{e) } \frac{1}{2} \\ - \frac{3}{8} \\ \hline \end{array}$$

$$\begin{array}{r} \text{f) } \frac{15}{16} \\ - \frac{3}{8} \\ \hline \end{array}$$

$$\begin{array}{r} \text{g) } \frac{9}{16} \\ - \frac{1}{8} \\ \hline \end{array}$$

$$\begin{array}{r} \text{h) } \frac{1}{6} \\ - \frac{1}{12} \\ \hline \end{array}$$

$$\begin{array}{r} \text{i) } \frac{4}{5} \\ - \frac{1}{10} \\ \hline \end{array}$$

6. Subtract. Be sure to reduce your answers to lowest terms.

$$\begin{array}{r} \text{a) } 20\frac{2}{4} \\ - 10\frac{3}{4} \\ \hline \end{array}$$

$$\begin{array}{r} \text{b) } 1\frac{2}{3} \\ - \frac{5}{6} \\ \hline \end{array}$$

$$\begin{array}{r} 4 \\ \text{c) } \underline{\quad \frac{1}{5}} \end{array}$$

$$\begin{array}{r} 4\frac{1}{5} \\ \text{d) } \underline{\quad 1\frac{2}{5}} \end{array}$$

$$\begin{array}{r} 5\frac{1}{3} \\ \text{e) } \underline{\quad \frac{2}{3}} \end{array}$$

$$\begin{array}{r} 9\frac{3}{5} \\ \text{f) } \underline{\quad 4\frac{4}{5}} \end{array}$$

7. Subtract the following fractions. Reduce your answer.

$$\begin{array}{r} 15\frac{1}{6} \\ \text{a) } \underline{\quad 3\frac{2}{5}} \end{array}$$

$$\begin{array}{r} 7 \\ \text{b) } \underline{\quad 4\frac{1}{3}} \end{array}$$

$$\begin{array}{r} 9\frac{1}{4} \\ \text{c) } \underline{\quad 7\frac{5}{8}} \end{array}$$

$$\begin{array}{r} 13\frac{1}{4} \\ \text{d) } \underline{\quad 3\frac{4}{9}} \end{array}$$

$$\begin{array}{r} 13 \\ \text{e) } - 1\frac{1}{5} \\ \hline \end{array}$$

$$\begin{array}{r} 7\frac{1}{3} \\ \text{f) } - 4\frac{5}{6} \\ \hline \end{array}$$

$$\begin{array}{r} 18\frac{1}{6} \\ \text{g) } - 14\frac{2}{9} \\ \hline \end{array}$$

$$\begin{array}{r} 4\frac{3}{5} \\ \text{h) } - 3\frac{3}{4} \\ \hline \end{array}$$

$$\begin{array}{r} 22 \\ \text{i) } - 1\frac{7}{12} \\ \hline \end{array}$$

$$\begin{array}{r} 19\frac{1}{8} \\ \text{j) } - 14\frac{1}{3} \\ \hline \end{array}$$

8. Solve the following problems.

- a) Cheryl walks for $\frac{1}{2}$ of an hour on Tuesdays and Thursdays, and $\frac{2}{3}$ of an hour on Mondays and Wednesdays. On Fridays, Saturdays and Sundays, she walks for $1\frac{1}{4}$ hours each day. How much time does she walk each week?

b) The car trip took $2\frac{2}{3}$ hours for 300 km. What was the average speed (in km per hour)?

c) The kids spent each day of their summer vacation in the lake! They would play in the water for 0.75 of an hour in the morning, $\frac{2}{3}$ of an hour after lunch, and then $1\frac{1}{2}$ hours before dinner. How many hours did they spend in the water during their 14 day vacation?

d) A freight truck has $26\frac{1}{4}$ kg of paper, $4\frac{3}{6}$ kg of pencils, $37\frac{1}{3}$ kg of file folders. How much weight was it carrying?

e) A flight from Fort Nelson to Vancouver takes $2\frac{5}{6}$ of an hour. If the plane has been flying for $1\frac{1}{4}$ of an hour, how much longer will the flight be?

f) If Henderson Lake's annual rain fall is $650\frac{6}{25}$ cm, and Ashcroft's is $15\frac{1}{4}$ cm, how much more rain does Henderson Lake get than Ashcroft each year?

g) A park is $12\frac{1}{2}$ km wide and $25\frac{1}{3}$ km long. What is the area of the park?

Answers to Unit 4 Review

1.)

- a) $\frac{2}{3}$ b) $\frac{5}{7}$ c) 1 d) $\frac{1}{2}$ e) $\frac{3}{4}$ f) $\frac{1}{3}$
g) $1\frac{1}{7}$ h) $\frac{2}{3}$

2.)

- a) $\frac{5}{6}$ b) $\frac{9}{10}$ c) $\frac{7}{12}$ d) $1\frac{7}{20}$ e) $1\frac{5}{28}$ f) $1\frac{5}{16}$
g) $\frac{11}{24}$ h) $\frac{59}{72}$ i) $1\frac{29}{63}$ j) $\frac{47}{60}$

3.)

- a) $9\frac{1}{35}$ b) $7\frac{3}{4}$ c) $7\frac{5}{8}$ d) $9\frac{17}{35}$ e) $5\frac{4}{15}$ f) $5\frac{11}{12}$
g) $13\frac{5}{6}$ h) $11\frac{1}{10}$ i) $12\frac{33}{35}$ j) $9\frac{7}{15}$

4.)

- a) $\frac{1}{5}$ b) $\frac{1}{2}$ c) $\frac{1}{3}$ d) $\frac{1}{6}$ e) $\frac{1}{2}$ f) $\frac{1}{3}$

5.)

- a) $\frac{1}{6}$ b) $\frac{1}{4}$ c) $\frac{2}{3}$ d) $\frac{1}{10}$ e) $\frac{1}{8}$ f) $\frac{9}{16}$
g) $\frac{7}{16}$ h) $\frac{1}{12}$ i) $\frac{7}{10}$

6.)

- a) $9\frac{3}{4}$ b) $\frac{5}{6}$ c) $3\frac{4}{5}$ d) $4\frac{4}{5}$ e) $4\frac{2}{3}$ f) $4\frac{4}{5}$

7.)

- a) $11\frac{23}{30}$ b) $2\frac{2}{3}$ c) $1\frac{5}{8}$ d) $9\frac{29}{36}$ e) $11\frac{4}{5}$ f) $2\frac{1}{2}$
g) $3\frac{17}{18}$ h) $\frac{17}{20}$ i) $20\frac{5}{12}$ j) $4\frac{19}{24}$

8.)

- a) Cheryl walked $6\frac{1}{12}$ hours each week.
b) The average was $112\frac{1}{2}$ km/hour
c) $38\frac{1}{2}$ hours in the lake
d) $68\frac{1}{12}$ kg
e) $1\frac{7}{12}$ hours left on the flight
f) Henderson Lake gets $634\frac{99}{100}$ cm more rain per year than Ashcroft.
g) $316\frac{2}{3}$ km²

It is now test time!

Please get the practice test from your instructor.

Once you are ready, you can get the
unit 4 test from your instructor.

Good luck!

Unit 5

Common Fractions & Decimals

Topic A: Common Fractions & Decimals

The amount represented by a fraction may be expressed as a common fraction, a decimal, or as a percent.

We choose common fractions, decimals, or percents for convenience and to fit the standard way of doing things.

Common fractions are used:

- For everyday conversation about parts of the whole thing ($\frac{1}{2}$ cup of coffee, $\frac{1}{4}$ of an hour, $\frac{3}{4}$ tank of gas)
- with amounts in the Imperial System of measurement which is standard in the United States and still used by some people in Canada
($3\frac{1}{4}$ feet, $\frac{5}{8}$ inches, $12\frac{3}{4}$ miles, $6\frac{1}{4}$ pounds, $1\frac{1}{2}$ teaspoons)
- For stock market reports and stock values
- For the score on the top of a test (which is usually changed to a percent)

Decimals are used

- with money (\$12.23)
- with the metric system of measurement (1.5 metres, 7.25 litres, 29.75 kilometres, 0.5 centimetres, 9.2 grams, 75.5 kilograms, etc.)
- whenever there is a lot of arithmetic calculation to be done
- for calculators and computers

Percents are used

- for reporting **statistics**
- for bank rates and interest charges such as mortgage rates
- for reading a grade on a test

Writing Decimals as Common Fractions

Remember this skill?

$$\text{a) } 0.48 = \frac{48}{100}$$

$$\text{b) } 3.542 = 3\frac{542}{1000}$$

Common fractions should always be in lowest terms.

$$\text{a) } 0.48 = \frac{48}{100} \left(\frac{\div 4}{\div 4} \right) = \frac{12}{25}$$

$$\text{b) } 3.542 = 3\frac{542}{1000} \left(\frac{\div 2}{\div 2} \right) = 3\frac{271}{500}$$

This list of factors may help you to simplify the fractions.

The factors of **10** are 1, 2, 5, 10

The factors of **100** are 1, 2, 4, 5, 10, 20, 25, 50, 100

The factors of **1 000** are 1, 2, 5, 8, 10, 20, 25, 50, 100, 125, 200, 250, 500, 1000

Remember: the whole number in a mixed decimal stays a whole number in a mixed fraction.

Exercise One

Write these decimals as common fractions expressed in lowest terms.

a) $16.04 = 16 \frac{4}{100} \frac{\div 4}{\div 4} = 16 \frac{1}{25}$

b) $0.085 = \frac{85}{1000} \frac{\div 5}{\div 5} = \frac{17}{200}$

c) $3.48 = \underline{\hspace{2cm}}$

d) $12.075 = \underline{\hspace{2cm}}$

e) $6.25 = \underline{\hspace{2cm}}$

f) $25.025 = \underline{\hspace{2cm}}$

g) $9.500 = \underline{\hspace{2cm}}$

h) $5.6 = \underline{\hspace{2cm}}$

i) $0.07 = \underline{\hspace{2cm}}$

j) $0.14 = \underline{\hspace{2cm}}$

k) $12.125 = \underline{\hspace{2cm}}$

l) $1.75 = \underline{\hspace{2cm}}$

Answers to Exercise One

c) $3 \frac{12}{25}$

d) $12 \frac{3}{40}$

e) $6 \frac{1}{4}$

f) $25 \frac{1}{40}$

g) $9 \frac{1}{2}$

h) $5 \frac{3}{5}$

i) $\frac{7}{100}$

j) $\frac{7}{50}$

k) $12 \frac{1}{8}$

l) $1 \frac{3}{4}$

Some Tricky Conversions

Do you remember that there are some fractions that do not convert into decimals perfectly? The reason they do not is because they have a repeating decimal.

Some are:

$$\frac{1}{6} = 0.1\bar{6} \quad ; \quad \frac{1}{3} = 0.\bar{3} \quad ; \quad \frac{2}{3} = 0.\bar{6} \quad ; \quad \frac{5}{6} = 0.8\bar{3} \quad ; \quad \frac{1}{9} = 0.\bar{1}$$

Because of this, it is not possible to convert a repeating decimal into a fraction perfectly either.

It is not possible to convert $0.1\bar{6}$ (which is really $0.166666666666\bar{6}$) into a fraction.

The only way to deal with this problem is: to remember that there are some tricky fractions that do not convert into perfect decimals.

Writing Common Fractions as Decimals

As you know, **common fractions** with denominators of 10, 100, 1 000, or 10 000 are easily written as decimals.

$$\frac{3}{10} = 0.3$$

$$\frac{21}{100} = 0.21$$

$$\frac{69}{1000} = 0.069$$

But if the denominator is not a 10, 100, etc., you may be able to change a **common fraction** to an **equivalent fraction** with a denominator of 10, 100, 1 000, or 10 000 which can then be written easily as a decimal. For example,

$$\frac{3}{5} \left(\frac{\times 2}{\times 2} \right) = \frac{6}{10} = 0.6$$

$$\frac{1}{2} \left(\frac{\times 5}{\times 5} \right) = \frac{5}{10} = 0.5$$

$$\frac{4}{25} \left(\frac{\times 4}{\times 4} \right) = \frac{16}{100} = 0.16$$

Exercise Two

Write as decimals.

a) $\frac{1}{2} = \frac{5}{10} = 0.5$

b) $\frac{2}{5} = \underline{\hspace{2cm}}$

c) $\frac{7}{10} = \underline{\hspace{2cm}}$

d) $\frac{4}{5} = \underline{\hspace{2cm}}$

e) $\frac{75}{100} = \underline{\hspace{2cm}}$

f) $\frac{3}{50} = \underline{\hspace{2cm}}$

g) $\frac{21}{1000} = \underline{\hspace{2cm}}$

h) $\frac{8}{25} = \underline{\hspace{2cm}}$

Answers to Exercise Two

b) 0.4

c) 0.7

d) 0.8

e) 0.75

f) 0.06

g) 0.021

h) 0.32

Here is a review of how to change a fraction to a decimal when it is not easy to make the denominator:

The line in a common fraction can be thought of as a divided by sign \div

To change a common fraction to a decimal, do this:

numerator \div denominator = the decimal equivalent

Example A: $\frac{3}{4}$ Think $3 \div 4$

$$\begin{array}{r} 0.75 \\ 4 \overline{)3.00} \\ \underline{28} \\ 20 \\ \underline{20} \\ 0 \end{array} \qquad \frac{3}{4} = 0.75$$

Example B: $\frac{3}{8}$ Think $3 \div 8$

$$\begin{array}{r} 0.375 \\ 8 \overline{)3.000} \\ \underline{24} \\ 60 \\ \underline{56} \\ 40 \\ \underline{40} \\ 0 \end{array} \qquad \frac{3}{8} = 0.375$$

Example C: $\frac{1}{3}$ Think $1 \div 3$

$$\begin{array}{r} 0.333 \\ 3 \overline{)1.000} \\ \underline{9} \\ 10 \\ \underline{9} \\ 10 \\ \underline{9} \\ 10 \end{array} \qquad \frac{1}{3} = 0.333$$

Exercise Three

Use the division method to write these common fractions as decimals.

$$\begin{array}{r} \text{a) } \frac{1}{2} \quad 2 \overline{)1.0} \\ \quad \underline{10} \\ \quad \quad 0 \end{array}$$

$$\text{b) } \frac{1}{4}$$

$$\frac{1}{2} = 0.5$$

$$\text{b) } \frac{2}{5}$$

$$\text{d) } \frac{6}{12}$$

$$\text{f) } \frac{1}{8}$$

$$\text{f) } \frac{3}{8}$$

$$\text{g) } \frac{5}{12}$$

$$\text{h) } \frac{1}{6}$$

$$\text{h) } \frac{2}{3}$$

$$\text{j) } \frac{19}{20}$$

Answers to Exercise Three

$$\text{b) } 0.25 \quad \text{c) } 0.4 \quad \text{d) } 0.5 \quad \text{e) } 0.125 \quad \text{f) } 0.375 \quad \text{g) } 0.4\overline{16}$$

$$\text{h) } 0.1\overline{6} \quad \text{i) } 0.\overline{6} \quad \text{j) } 0.95$$

The whole number in a mixed fraction stays a whole number in a mixed decimal. Rewrite the whole number to the left of the decimal. Then change the common fraction to a decimal.

$$4\frac{3}{4} = 4.75$$

$$\text{Think } \frac{3}{4} = 3 \div 4 = 0.75$$

$$16\frac{1}{2} = 16.5$$

$$\text{Think } \frac{1}{2} = 1 \div 2 = 0.5$$

Exercise Four

Complete the chart of **equivalent common fractions and decimals**. Use this chart as a **reference** for yourself in later work. Look for patterns that develop and note them in the margin.

| Common Fraction | Decimal |
|---|---------|
| $\frac{1}{8}$ | |
| $\frac{2}{8} = \frac{1}{4}$ | |
| $\frac{3}{8}$ | |
| $\frac{4}{8} = \frac{2}{4} = \frac{1}{2}$ | |
| $\frac{5}{8}$ | |
| $\frac{6}{8} = \frac{3}{4}$ | |
| $\frac{7}{8}$ | |
| $\frac{8}{8} = \frac{4}{4} = \frac{2}{2} = 1$ | |
| $\frac{1}{12}$ | |
| $\frac{2}{12} = \frac{1}{6}$ | |
| $\frac{4}{12} = \frac{2}{6} = \frac{1}{3}$ | |

| Common Fraction | Decimal |
|---|---------|
| $\frac{6}{12} = \frac{3}{6} = \frac{1}{2}$ | |
| $\frac{8}{12} = \frac{4}{6} = \frac{2}{3}$ | |
| $\frac{10}{12} = \frac{5}{6}$ | |
| $\frac{12}{12} = \frac{6}{6} = \frac{3}{3}$ | |
| $\frac{1}{20}$ | |
| $\frac{2}{20} = \frac{1}{10}$ | |
| $\frac{2}{10} = \frac{1}{5}$ | |
| $\frac{4}{10} = \frac{2}{5}$ | |
| $\frac{6}{10} = \frac{3}{5}$ | |
| $\frac{8}{10} = \frac{4}{5}$ | |
| $\frac{10}{10} = \frac{5}{5} = 1$ | |

Answers to Exercise Four

| Common Fraction | Decimal |
|---|---------------|
| $\frac{1}{8}$ | 0.125 |
| $\frac{2}{8} = \frac{1}{4}$ | 0.25 |
| $\frac{3}{8}$ | 0.375 |
| $\frac{4}{8} = \frac{2}{4} = \frac{1}{2}$ | 0.5 |
| $\frac{5}{8}$ | 0.625 |
| $\frac{6}{8} = \frac{3}{4}$ | 0.75 |
| $\frac{7}{8}$ | 0.875 |
| $\frac{8}{8} = \frac{4}{4} = \frac{2}{2} = 1$ | 1.0 |
| $\frac{1}{12}$ | $0.08\bar{3}$ |
| $\frac{2}{12} = \frac{1}{6}$ | $0.1\bar{6}$ |
| $\frac{4}{12} = \frac{2}{6} = \frac{1}{3}$ | $0.\bar{3}$ |
| $\frac{6}{12} = \frac{3}{6} = \frac{1}{2}$ | 0.5 |

| Common Fraction | Decimal |
|---|--------------|
| $\frac{8}{12} = \frac{4}{6} = \frac{2}{3}$ | $0.\bar{6}$ |
| $\frac{10}{12} = \frac{5}{6}$ | $0.8\bar{3}$ |
| $\frac{12}{12} = \frac{6}{6} = \frac{3}{3}$ | 1.0 |
| $\frac{1}{20}$ | 0.05 |
| $\frac{2}{20} = \frac{1}{10}$ | 0.1 |
| $\frac{2}{10} = \frac{1}{5}$ | 0.2 |
| $\frac{4}{10} = \frac{2}{5}$ | 0.4 |
| $\frac{6}{10} = \frac{3}{5}$ | 0.6 |
| $\frac{8}{10} = \frac{4}{5}$ | 0.8 |
| $\frac{10}{10} = \frac{5}{5} = 1$ | 1.0 |

You may work with problems and real-life situations that use one decimal and one common fraction. Rewrite the fractions so both are decimals or both are common fractions. Choose the fraction form that will give the answer the way it should be written.

Example A: Ted worked $3\frac{3}{4}$ hours at \$8.25 per hour. How much did he earn?
(Round to the nearest cent.)

The answer will be money which should be written using decimals, so work in the decimal form.

Rewrite $3\frac{3}{4}$ hours as 3.75 hours.

Ted earned $3.75 \times \$8.25 = \30.94

Example B: Jane cycled 49.4 km in $2\frac{1}{2}$ hours. What was her average speed?

The answer will be in km/hr. Metric measurements are written with decimals, so work in decimals.

Rewrite $2\frac{1}{2}$ hours as 2.5 hours and solve the problem.

$49.4 \div 2.5 = 19.76$ km/hr.

Topic A Self Test

Mark /11 Aim /11

A. Complete the chart.

7 marks

| | Common Fraction | Decimal |
|---|-----------------|-------------|
| a | $\frac{1}{4}$ | |
| b | | 0.125 |
| c | | $0.\bar{3}$ |
| d | $\frac{3}{4}$ | |
| e | | 0.875 |
| f | $\frac{3}{5}$ | |
| g | $\frac{6}{6}$ | |

B. Answer the following word problems.

4 marks

a) Joseph worked $5\frac{3}{4}$ hours a day, 5 days a week. He gets paid \$ 9.35 per hour. How much does he get paid a week?

b) Giang ran a 42.195 km marathon in $4\frac{1}{4}$ hours. What was her average speed rounded to two decimal places?

Answers to Self Test

A.

| | Common Fraction | Decimal |
|---|-----------------|-------------|
| a | $\frac{1}{4}$ | 0.25 |
| b | $\frac{1}{8}$ | 0.125 |
| c | $\frac{1}{3}$ | $0.\bar{3}$ |
| d | $\frac{3}{4}$ | 0.75 |
| e | $\frac{7}{8}$ | 0.875 |
| f | $\frac{3}{5}$ | 0.6 |
| g | $\frac{6}{6}$ | 1 |

B. a) \$261.81 b) 9.93 km/hr

Topic B: Comparing Fractions and Decimals

In Unit 2 you compared simple fractions to simple fractions such as $\frac{1}{2}$ _____ $\frac{1}{3}$.

Now, you are going to be asked to compare fractions with larger and less common denominators such as $\frac{7}{8}$ and $\frac{17}{28}$.

Find the equivalent fractions of both the fractions and then compare.

$$\frac{1}{2} \left(\frac{\times 3}{\times 3} \right) = \frac{3}{6} \text{ _____ } \frac{1}{3} \left(\frac{\times 2}{\times 2} \right) = \frac{2}{6} \longrightarrow \frac{3}{6} \geq \frac{2}{6}$$

$$\frac{7}{8} \left(\frac{\times 7}{\times 7} \right) = \frac{49}{56} \text{ _____ } \frac{17}{28} \left(\frac{\times 2}{\times 2} \right) = \frac{34}{56} \longrightarrow \frac{49}{56} \geq \frac{34}{56}$$

Exercise One

Change the fractions to have the same denominators. Decide which is larger. Use $>$, $<$, $=$ to mark your answer. There is space below each problem to work out your equivalent fractions.

a) $\frac{1}{4}$ _____ $\frac{3}{5}$

b) $\frac{5}{8}$ _____ $\frac{3}{4}$

c) $\frac{1}{5}$ _____ $\frac{2}{3}$

d) $\frac{4}{5}$ _____ $\frac{3}{4}$

e) $\frac{2}{3}$ _____ $\frac{3}{4}$

f) $\frac{5}{8}$ _____ $\frac{3}{5}$

$$g) \frac{49}{56} \text{ ————— } \frac{3}{4}$$

$$h) \frac{75}{90} \text{ ————— } \frac{10}{11}$$

$$i) \frac{3}{5} \text{ ————— } \frac{1}{3}$$

$$j) \frac{33}{70} \text{ ————— } \frac{1}{2}$$

$$k) \frac{14}{15} \text{ ————— } \frac{9}{10}$$

$$l) \frac{1}{3} \text{ ————— } \frac{1}{9}$$

Answers to Exercise One

a) < b) < c) < d) > e) < f) < g) > h) < i) > j) < k) > l) >

Comparing Fractions to Decimals and Decimals to Fractions

Now that you know how to convert between fractions and decimals, you are also going to be able to compare them.

Example A:

Which is larger: $\frac{3}{8}$ or 0.125?

1) Decide to convert either the fraction into a decimal, or the decimal into a fraction.

Let's pick converting the fraction to a decimal.

2) Do the conversion: $\frac{3}{8} =$

$$\begin{array}{r} 0.375 \\ 8 \overline{) 3.000} \\ \underline{-24} \downarrow \\ 60 \downarrow \\ \underline{-56} \\ 40 \\ \underline{-40} \\ 0 \end{array} = 0.375$$

3) Compare $0.375 \underline{\hspace{1cm}} > \underline{\hspace{1cm}} 0.125$

4) Write a math sentence to show your answer: $\frac{3}{8} \underline{\hspace{1cm}} > \underline{\hspace{1cm}} 0.125$

Example B:

Which is larger $\frac{7}{8}$ or 0.6?

1) Pick which you will convert, the decimal into the fraction, or the fraction into the decimal.

Let's pick converting the decimal this time.

2) Convert $0.6 = \frac{6}{10} \left(\begin{array}{l} \div 2 \\ \div 2 \end{array} \right) = \frac{3}{5}$

3) Compare $\frac{7}{8} \underline{\hspace{1cm}} \frac{3}{5} \longrightarrow \frac{7}{8} \left(\begin{array}{l} \times 5 \\ \times 5 \end{array} \right) = \frac{35}{40} \underline{\hspace{1cm}} > \underline{\hspace{1cm}} \frac{3}{5} \left(\begin{array}{l} \times 8 \\ \times 8 \end{array} \right) = \frac{24}{40}$

4) Write a math sentence to show your answer: $\frac{7}{8} \underline{\hspace{1cm}} > \underline{\hspace{1cm}} 0.6$

You may find that converting the fractions to the decimals could speed things up.

Exercise Two

Compare the following numbers to each other. Use $>$ or $<$.

a) 0.25 _____ $\frac{1}{5}$

b) $\frac{1}{8}$ _____ 0.8

c) $\frac{1}{6}$ _____ 0.125

d) 0.875 _____ $\frac{5}{6}$

e) 0.625 _____ $\frac{3}{5}$

f) $\frac{4}{5}$ _____ 0.75

g) 0.2 _____ $\frac{3}{10}$

h) 0.375 _____ $\frac{2}{3}$

i) $\frac{2}{5}$ _____ 0.5

j) 0.375 _____ $\frac{1}{5}$

Answers to Exercise Two

a) $>$ b) $<$ c) $>$ d) $>$ e) $>$ f) $>$ g) $<$ h) $<$ i) $<$ j) $>$

Exercise Three

Compare the following numbers to each other.

a) 0.345 _____ $\frac{6}{7}$

b) $\frac{32}{71}$ _____ 0.42

c) $\frac{1}{1051}$ _____ 0.0032

d) 0.337 _____ $\frac{5}{26}$

e) 0.52 _____ $\frac{10}{21}$

f) $\frac{75}{90}$ _____ 0.473

g) 0.6894 _____ $\frac{103}{278}$

h) 0.9993 _____ $\frac{44}{47}$

i) $\frac{1}{72}$ _____ 0.034

j) 0.5642 _____ $\frac{5}{9}$

Answers to Exercise Three

a) < b) > c) < d) > e) < f) > g) > h) > i) < j) >

Topic B Self-Test

Mark /18 Aim 15/18

A. Write as common fractions in lowest terms.

4 marks

a) 3.6

b) 8.125

c) 0.75

d) 0.45

B. Write as decimals. Round your answers to 3 decimal places.

4 marks

a) $\frac{1}{3}$

b) $\frac{6}{100}$

c) $\frac{3}{8}$

d) $\frac{5}{7}$

C. Compare the following fractions and decimals, use <, or >.

6 marks

a) 0.862 _____ $\frac{6}{7}$

b) $\frac{3}{14}$ _____ 0.35

c) $\frac{1}{10}$ _____ 0.007

d) 0.3 _____ $\frac{20}{26}$

e) 0.5 _____ $\frac{10}{21}$

f) $\frac{89}{90}$ _____ 0.473

D. Problems 4 marks

a) May babysat for $4\frac{1}{4}$ hours. She is paid \$4.75 an hour. How much did she earn?

b) Diane bought 1.5 litres of milk. Her thirsty kids drank half of it as soon as she got home. How much milk is left?

Answers to Topic B Self-Test

Part A

a) $3\frac{3}{5}$ b) $8\frac{1}{8}$ c) $\frac{3}{4}$ d) $\frac{9}{20}$

Part B

a) $0.\overline{3}$ b) 0.06 c) 0.375 d) 0.714

Part C

a) > b) < c) > d) < e) > f) >

Part D

a) \$20.19 b) 0.75 L

Unit 5 Review

1) Write as common fractions in lowest terms.

a) 3.5

b) 8.625

c) 0.25

d) 0.375

e) 4.125

f) 10.4

g) 2.6

g) 3.05

2) Write as decimals. Round your answers to 3 decimal places.

a) $\frac{2}{3}$

b) $\frac{12}{100}$

c) $\frac{5}{8}$

d) $\frac{6}{7}$

e) $\frac{3}{8}$

f) $\frac{1}{6}$

g) $\frac{17}{25}$

h) $\frac{5}{6}$

i) $\frac{1}{5}$

j) $\frac{1}{3}$

3) Compare the following fractions to fractions, use $<$, or $>$.

a) $\frac{1}{4}$ _____ $\frac{6}{7}$

b) $\frac{3}{14}$ _____ $\frac{7}{49}$

c) $\frac{1}{10}$ _____ $\frac{6}{30}$

d) $\frac{9}{13}$ _____ $\frac{20}{26}$

e) $\frac{1}{3}$ _____ $\frac{10}{21}$

f) $\frac{8}{9}$ _____ $\frac{6}{7}$

4) Compare the following fractions to decimals. Use $>$, $<$, or $=$

a) 0.8 _____ $\frac{6}{7}$

b) $\frac{3}{7}$ _____ 0.52

c) $\frac{1}{5}$ _____ 0.20

d) 0.125 _____ $\frac{5}{8}$

e) 0.63 _____ $\frac{7}{25}$

f) $\frac{65}{90}$ _____ 0.4

g) $0.45 \text{ --- } \frac{19}{27}$

h) $0.99 \text{ --- } \frac{1}{4}$

i) $\frac{1}{7} \text{ --- } 0.39$

j) $0.375 \text{ --- } \frac{3}{8}$

Answers to Unit 5 Review

1)

a) $3\frac{1}{2}$

b) $8\frac{5}{8}$

c) $\frac{1}{4}$

d) $\frac{3}{8}$

e) $4\frac{1}{8}$

f) $10\frac{2}{5}$

g) $2\frac{3}{5}$

h) $3\frac{1}{20}$

2)

a) 0.667

b) 0.12

c) 0.625

d) 0.857

e) 0.375

f) 0.167

g) 0.68

h) $0.8\bar{3}$

i) 0.2

j) $0.\bar{3}$

3)

a) <

b) >

c) <

d) <

e) <

f) >

4)

a) <

b) <

c) =

d) <

e) >

f) >

g) <

h) >

i) <

j) =

It is now Test time.

Please see your instructor
to get the practice test.

Once you are prepared,
you can write the unit 5 test.
Your instructor will get that for you too!

Once you have completed the unit 6 test,
it will be time to write the final test.

Good luck!

Book Five Final Review

You will now practice all the skills you learned in Book 5. You can use this as a review for your final test.

If you can't remember how to do a question, go back to the lesson on this topic to refresh your memory. The unit and topic for where each question came from is listed next to the question.

Example: **1A** means Unit 1, Topic A

1-A

1. Write in lowest terms the common fractions to describe the shaded portion of each shape.

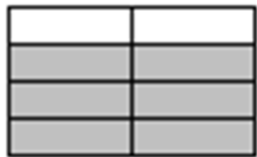

a) _____



b) _____

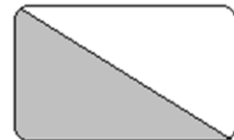

c) _____

2. Draw your own fractions.

a) $\frac{1}{5}$

b) $\frac{3}{7}$

3. Answer the questions using a common fraction, in lowest terms.

a) Rattan ran for 40 minutes. What fraction of an hour did he run?

b) Oliver answered 23 of the 27 questions on his test. What fraction of questions did he answer?

c) Belle got 49 marks on the test. The test was out of 56. What was her score?

1-B

4. Identify each fraction by writing: **proper fraction, improper fraction, or mixed number** next to each fraction.

a) $\frac{5}{2}$ _____

b) $2\frac{1}{3}$ _____

c) $\frac{4}{5}$ _____

d) $\frac{7}{3}$ _____

5. Write the improper fraction and the equivalent mixed number that describe the shaded part in each drawing.

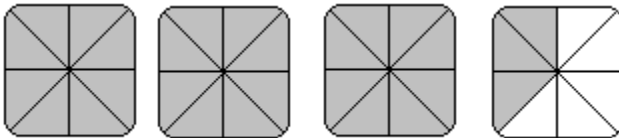

a) _____

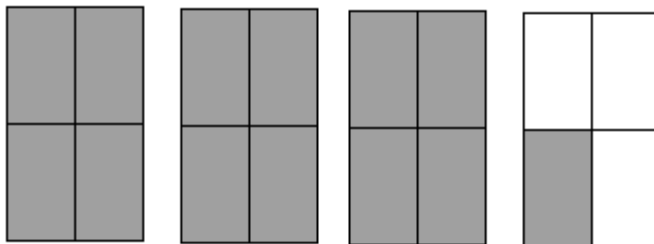

b) _____

6. Rename each proper fraction into a mixed number.

a) $\frac{11}{5} = \underline{\hspace{2cm}}$

b) $\frac{15}{4} = \underline{\hspace{2cm}}$

c) $\frac{19}{6} = \underline{\hspace{2cm}}$

7. Rename each whole number as an improper fraction. Use the denominator given to you.

a) $5 = \frac{\hspace{1cm}}{2}$

b) $3 = \frac{\hspace{1cm}}{5}$

c) $8 = \frac{\hspace{1cm}}{3}$

8. Rename each mixed number as an improper fraction.

a) $2\frac{3}{8} = \underline{\hspace{2cm}}$

b) $6\frac{5}{9} = \underline{\hspace{2cm}}$

c) $1\frac{2}{3} = \underline{\hspace{2cm}}$

2-A

9. Find the factors, common factors and the Greatest Common Factor (G.C.F.)

| | Fraction | Factors | Common Factors | G.C.F |
|---|-----------------|----------------|-----------------------|--------------|
| a | $\frac{4}{22}$ | | | |
| b | $\frac{12}{48}$ | | | |
| c | $\frac{27}{36}$ | | | |
| d | $\frac{12}{40}$ | | | |

10. Express each fraction in lowest terms.

a) $\frac{7}{21} =$ _____

b) $\frac{9}{24} =$ _____

c) $\frac{10}{250} =$ _____

d) $\frac{12}{36} =$ _____

11. State if each pair of fractions is equivalent (=) or not equivalent (\neq) by placing the correct sign between them.

a) $\frac{3}{4}$ _____ $\frac{31}{42}$

b) $\frac{1}{7}$ _____ $\frac{5}{35}$

c) $\frac{4}{13}$ _____ $\frac{6}{39}$

d) $\frac{1}{3}$ _____ $\frac{11}{13}$

12. Round to the nearest whole number.

a) $2\frac{1}{6}$ _____

b) $1\frac{4}{5}$ _____

c) $\frac{3}{5}$ _____

3-A

13. Write the multiplication equation you would use to find the answer to the question.

Do not calculate the answer.

- a) Joona peeled $\frac{3}{4}$ of the 35 kilograms of apples. How many kilograms of apples did Joona peel?

b) There are 16 bottles of ketchup in the restaurant. They are each $\frac{1}{4}$ full. How many full bottles of ketchup would there be, if all the ketchup bottles were put together?

c) Half a recipe that needs $2\frac{2}{3}$ cups of sugar.

d) The community pool has a capacity of 150 swimmers. The pool is $\frac{1}{5}$ full, how many swimmers are there?

14. Find the products. Make sure your answers are in lowest terms.

a) $\frac{1}{3} \times \frac{4}{5} =$

b) $\frac{1}{3}$ of 34 =

c) $4 \times \frac{3}{5} =$

d) $\frac{5}{7}$ of $1\frac{1}{5} =$

e) $2\frac{1}{2} \times 7\frac{1}{2} =$

f) $\frac{3}{4} \times \frac{1}{7} \times 4\frac{5}{9} =$

15. Solve the following word problems.

- a) Thu saves $\frac{1}{5}$ of her income for the down payment on a house. If her annual income is \$34 458.00, how much can she save in one year?
- b) $\frac{1}{3}$ of the students at one Vancouver college speaks a language other than English. $\frac{3}{4}$ of those students are studying ESL. What fraction of the students are studying ESL?
- c) A recipe calls for $1\frac{1}{2}$ cups of sugar. How much sugar should be used if the recipe is being tripled?

d) Find the area of the rectangle

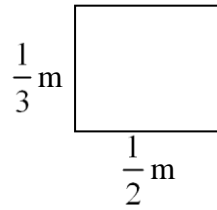

e) A corner store sells 2 345 items in one day. $\frac{4}{5}$ of those items are junk food. How many of the items are junk food?

16. Divide the following fractions. Show all your work, and make sure your answers in the lowest terms.

a) $\frac{1}{3} \div \frac{3}{4} =$

b) $\frac{1}{2} \div \frac{3}{5} =$

c) $\frac{3}{5} \div 9 =$

d) $3\frac{2}{3} \div \frac{1}{2} =$

e) $5\frac{1}{5} \div \frac{6}{7} =$

f) $4\frac{1}{3} \div 2\frac{2}{5} =$

17. Solve the following word problems

- a) Kathy worked on planting garlic last weekend. It took her $3\frac{1}{2}$ minutes to plant one row. How many rows did she plant in $\frac{1}{3}$ of an hour?

(one hour = 60 minutes)

- b) Nicole knits socks in the evenings. It takes her $7\frac{1}{3}$ hours to knit one sock. How many hours does it take to knit a pair of socks (that is 2 socks) ?

- c) Last week Nicole knit for a total of $27\frac{1}{2}$ hours. **Approximately** how many socks could she knit in that time? (To get an approximate, round your numbers to whole numbers first)

- d) Faisal travels $43\frac{1}{3}$ km on the sky train each week. He travels 5 days a week.
How far does he travel each day?

- e) A baking sheet is $39\frac{3}{5}$ cm by $18\frac{1}{4}$ cm. Find its area.

4-A

18. Add these common fractions, make sure to reduce your answer to the lowest terms.

a)
$$\begin{array}{r} \frac{1}{5} \\ + \frac{4}{5} \\ \hline \end{array}$$

b)
$$\begin{array}{r} \frac{3}{5} \\ + \frac{6}{7} \\ \hline \end{array}$$

c) $\frac{2}{7} + \frac{3}{4} =$

d) $\frac{2}{3} + \frac{5}{9} =$

e)
$$\begin{array}{r} \frac{5}{12} \\ + \frac{5}{8} \\ \hline \end{array}$$

f)
$$\begin{array}{r} \frac{2}{3} \\ + \frac{5}{6} \\ \hline \end{array}$$

19. Add these mixed numbers, express the sum in the lowest terms.

$$\begin{array}{r} \text{a) } 4\frac{2}{5} \\ +7\frac{4}{7} \\ \hline \end{array}$$

$$\text{b) } 2\frac{1}{3} + 4\frac{3}{4} =$$

$$\text{c) } 1\frac{2}{3} + 3\frac{1}{2} + 3\frac{3}{4} =$$

$$\text{d) } 4\frac{1}{8} + 1\frac{1}{4} =$$

$$\begin{array}{r} \text{e) } 4\frac{1}{9} \\ +2\frac{2}{3} \\ \hline \end{array}$$

$$\begin{array}{r} \text{f) } 2\frac{7}{15} \\ +10\frac{1}{5} \\ \hline \end{array}$$

20. Subtract these common fractions. Express your answer in lowest terms.

$$\begin{array}{r} \text{a) } \frac{5}{12} \\ -\frac{1}{3} \\ \hline \end{array}$$

$$\begin{array}{r} \text{b) } \frac{5}{6} \\ -\frac{3}{4} \\ \hline \end{array}$$

$$\begin{array}{r} \text{c) } \frac{1}{2} \\ -\frac{9}{24} \\ \hline \end{array}$$

$$\text{d) } \frac{4}{5} - \frac{1}{4} =$$

$$\text{e) } \frac{30}{35} - \frac{2}{5} =$$

$$\text{f) } \frac{1}{2} - \frac{5}{12} =$$

21. Subtract these mixed numbers, express your answer in lowest terms.

$$\begin{array}{r} \text{a) } 7\frac{2}{3} \\ -2\frac{1}{6} \\ \hline \end{array}$$

$$\begin{array}{r} \text{b) } 2\frac{4}{7} \\ -1\frac{5}{21} \\ \hline \end{array}$$

$$\begin{array}{r} \text{c) } 9\frac{1}{5} \\ -4\frac{4}{25} \\ \hline \end{array}$$

$$\text{d) } 3\frac{1}{2} - 1\frac{4}{7} =$$

$$\text{e) } 6\frac{1}{8} - 3\frac{3}{4} =$$

$$\text{f) } 5\frac{1}{2} - 2\frac{7}{8} =$$

22. Solve the following word problems.

- a) A concrete contractor needs $6\frac{1}{3}$ metre of wire mesh for a concrete walkway and $12\frac{3}{8}$ metres of wire mesh for a driveway. If the contractor starts with a roll that is $54\frac{1}{4}$ metres long, how much wire mesh is left at the end of the two jobs?

b) Frida and Sean collect returnable bottles and cans. Frida has $3\frac{1}{3}$ bags of returnables. Sean has $4\frac{1}{2}$ bags to return. How much more does Sean have than Frida?

c) Mike bought $5\frac{1}{4}$ metres of silk to sew three shirts. Each shirt took $1\frac{3}{5}$ of material. How much silk is left over?

d) A freight container is loaded with 3 groups of products. Group A weighs $58\frac{1}{2}$ tons, Group B weighs $23\frac{5}{8}$ tons and Group C weighs $29\frac{1}{4}$ tons. Find the weight of the products.

- e) If the loaded container in question d) is $189\frac{3}{5}$ tons, what is the weight of the empty container?

5-A

23. Write as a common fraction in lowest terms.

- a) 0.75 _____ b) $0.1\bar{6}$ _____
c) 0.1 _____ d) 0.4 _____
e) 1.6 _____ f) 2.625 _____
g) $3.\bar{3}$ _____ h) 0.125 _____

24. Write as decimals. Round your answer to 3 decimal places.

- a) $\frac{3}{8}$ _____ b) $\frac{1}{3}$ _____
c) $\frac{3}{4}$ _____ d) $\frac{1}{20}$ _____
e) $\frac{1}{8}$ _____ f) $1\frac{2}{3}$ _____
g) $\frac{1}{5}$ _____ h) $\frac{6}{6}$ _____

25. Compare the following fractions, use < or >.

a) $\frac{2}{3}$ _____ $\frac{1}{4}$

b) $\frac{2}{5}$ _____ $\frac{4}{7}$

c) $\frac{5}{9}$ _____ $\frac{1}{3}$

d) $\frac{7}{12}$ _____ $\frac{2}{3}$

26. Compare the following fractions to decimals. Use < , > , or =.

a) $\frac{1}{2}$ _____ 0.5

b) $\frac{2}{3}$ _____ 0.625

c) 0.125 _____ $\frac{1}{8}$

d) $\frac{4}{9}$ _____ 0.6

e) 3.45 _____ $3\frac{1}{6}$

f) $\frac{1}{5}$ _____ 0.3

Answers to Book Five Final Review:

1. a) $\frac{3}{4}$ b) $\frac{1}{4}$ c) $\frac{1}{2}$

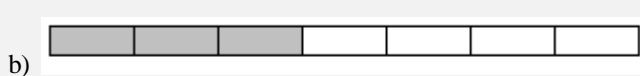

3. a) $\frac{2}{3}$ b) $\frac{23}{27}$ c) $\frac{7}{8}$

4. a) improper fraction b) mixed number c) proper fraction d) improper fraction

5. a) $\frac{27}{8}$, $3\frac{3}{8}$ b) $\frac{13}{4}$, $3\frac{1}{4}$

6. a) $2\frac{1}{5}$ b) $3\frac{3}{4}$ c) $3\frac{1}{6}$

7. a) 10 b) 15 c) 24

8. a) $\frac{19}{8}$ b) $\frac{59}{9}$ c) $\frac{5}{2}$

| 9. | Fraction | Factors | Common Factors | G.C.F |
|----|-----------------|---|----------------|-------|
| a | $\frac{4}{22}$ | 1, 2, 4 1, 2, 11, 22 | 2 | 2 |
| b | $\frac{12}{48}$ | 1, 2, 3, 4, 6, 12 1, 2, 3, 4, 6, 8, 12, 16, 24, 48 | 2, 3, 4, 6, 12 | 12 |
| c | $\frac{27}{36}$ | 1, 3, 9, 27 1, 2, 3, 4, 6, 9, 12, 18, 36 | 3, 9 | 9 |
| d | $\frac{12}{40}$ | 1, 2, 3, 4, 6, 12 1, 2, 4, 5, 8, 10, 20, 40 | 2, 4, | 4 |

10. a) $\frac{1}{3}$ b) $\frac{3}{8}$ c) $\frac{1}{25}$ d) $\frac{1}{3}$

11. a) \neq b) $=$ c) \neq d) \neq

12. a) 2 b) 2 c) 1
13. a) $\frac{3}{4} \times \frac{35}{1}$ b) $16 \times \frac{1}{4}$ c) $\frac{1}{2} \times 2\frac{2}{3}$ d) $150 \times \frac{1}{5}$
14. a) $\frac{4}{15}$ b) $11\frac{1}{3}$ c) $2\frac{2}{5}$ d) $\frac{6}{7}$ e) $18\frac{3}{4}$ f) $\frac{41}{84}$
15. a) \$ 6891 $\frac{3}{5}$ b) $\frac{1}{4}$ c) $4\frac{1}{2}$ cups d) $\frac{1}{6}$ m² e) 1867
16. a) $\frac{4}{9}$ b) $\frac{5}{6}$ c) $\frac{1}{15}$ d) $7\frac{1}{3}$ e) $30\frac{1}{3}$ f) $1\frac{29}{36}$
17. a) 70 rows b) $14\frac{2}{3}$ hours c) 4 socks d) $8\frac{2}{3}$ km e) $722\frac{7}{10}$ cm²
18. a) 1 b) $1\frac{16}{35}$ c) $1\frac{1}{28}$ d) $1\frac{2}{9}$ e) $1\frac{1}{24}$ f) $1\frac{1}{2}$
19. a) $11\frac{34}{35}$ b) $7\frac{1}{12}$ c) $9\frac{1}{12}$ d) $5\frac{3}{8}$ e) $6\frac{7}{9}$ f) $12\frac{2}{3}$
20. a) $\frac{1}{12}$ b) $\frac{1}{12}$ c) $\frac{1}{8}$ d) $\frac{11}{25}$ e) $\frac{16}{35}$ f) $\frac{1}{12}$
21. a) $5\frac{1}{2}$ b) $1\frac{1}{3}$ c) $5\frac{1}{25}$ d) $1\frac{13}{14}$ e) $2\frac{3}{8}$ f) $2\frac{5}{8}$
22. a) $35\frac{13}{24}$ m b) $1\frac{1}{6}$ more c) $\frac{9}{20}$ metres d) $113\frac{3}{8}$ tonnes e) $76\frac{9}{40}$ tonnes
23. a) $\frac{3}{4}$ b) $\frac{1}{6}$ c) $\frac{1}{10}$ d) $\frac{2}{5}$ e) $1\frac{3}{5}$ f) $2\frac{5}{8}$
- g) $3\frac{1}{3}$ h) $\frac{1}{8}$
24. a) 0.375 b) $0.\bar{3}$ c) 0.75 d) 0.05 e) 0.125 f) $1.\bar{6}$
- g) 0.2 h) 1
25. a) > b) < c) > d) <
26. a) = b) > c) = d) < e) > f) <

Glossary

Addends The numbers to be added together in an addition question. In $3 + 5 = 8$, the addends are 3 and 5.

Axis Any straight line used for measuring or as a reference.

Balance Balance has many meanings. In money matters, the balance is the amount left. It might be the amount left in a bank account (bank balance) or it might be the amount you still must pay on a bill (balance owing).

Cancelled cheque A cheque that has been cashed. The cheque is stamped, or cancelled, so it is no longer negotiable.

Circumference The distance around a circle; the perimeter of a circle.

Commission Salespeople may be paid a percentage of the money made in sales. The commission is part or all their earnings.

Common fractions eg, $\frac{2}{3}$, $\frac{3}{7}$, $\frac{49}{50}$

Cross multiply In a proportion, multiply the numerator of the first fraction times the denominator of the second fraction. Then multiply the denominator of the first fraction times the numerator of the second fraction. In a true proportion, the products of the cross multiplication are equal.

Denominator The bottom number in a common fraction; the denominator tells into how many equal parts the whole thing has been divided.

Diameter The distance across a circle through its centre.

Difference The result of a subtraction question, the answer. Subtraction gives the difference between two numbers.

Digit Any of the ten numerals (0 to 9) are digits. This term comes from our ten fingers which are called digits. The numerals came to be called "digits" from the practice of counting on the fingers!

Discount An amount taken off the regular cost. If something is bought "at a discount" it is bought at less than the regular price.

Divide To separate into equal parts.

Dividend The number or quantity to be divided; what you start with before you divide.

Divisor The number of groups or the quantity into which a number (the dividend) is to be separated.

Equal = The same as

Equation A mathematical statement that two quantities are equal. An equation may use numerals with a letter to stand for an unknown quantity. $6 + Y = 9$.

Equivalent Equal in value; equivalent numbers (whole or fractions) can be used interchangeably; that is, they can be used instead of each other.

Estimate Make an approximate answer. Use the sign \approx to mean approximately equal.

Factors The numbers or quantities that are multiplied together to form a given product. $5 \times 2 = 10$, so 5 and 2 are factors of 10.

Fraction Part of the whole; a quantity less than one unit.

Horizontal In a flat position; we are horizontal when we lie in a bed. A horizontal line goes across the page.

Improper fraction A common fraction with a value equal to or more than one.

Infinite Without end, without limit.

Invert To turn upside down.

Like fractions With the same denominators.

Lowest terms When the terms of a common fraction or ratio do not have a common factor (except 1), the fraction or ratio are in lowest terms (also called simplest form).

Minuend The first number in a subtraction question.

Mixed number A whole number and a common fraction. $1 \frac{3}{4}$

Mixed decimal A whole number and a decimal fraction. 1.75

Multiple If a certain number is multiplied by another number, the product is a multiple of the numbers. Think of the multiplication tables. For example, 2, 4, 6, 8, 10, 12, 14...are multiples of 2.

Multiplicand The number to be multiplied.

Multiplier The number you multiply by.

Negotiable Something which can be cashed, that is, exchanged or traded as money.

Numbers Numbers represent the amount, the place in a sequence; *number* is the idea of quantity or order.

Numerals The digits 1,2,3,4,5,6,7,8,9,0 are also called numerals. These ten digits are combined to make infinite numerals. Digits are like the letters, numerals are like the words and numbers are the meaning.

Numerator The top number in a common fraction; the numerator tells how many parts of the whole thing are being considered.

Overdrawn If the value of the cheques or money taken from a bank account is higher than the amount of money in the account, then the account is overdrawn. The account is "in the hole" or "in the red" are expressions sometimes used.

Parallel Two objects or lines side by side, never crossing and always the same distance from each other. Railway tracks are parallel, the lines on writing paper are parallel.

Percent (%) For every one hundred.

Perimeter The distance around the outside of a shape.

Place value We understand numbers by the way the digits (numerals) are arranged in relationship to each other and to the decimal point. Each position has a certain value. Our number system is a **decimal system**. The place value is based on **ten**.

Prime number A number that can only be divided evenly by itself and 1.

Product The result of a multiplying question, the answer.

Proper fraction A common fraction with a value less than one.

Proportion Generally, proportion is a way of comparing a part of something to the whole thing. Eg. his feet are small in proportion to his height. In mathematics, proportion is used to describe two or more ratios that are equivalent to each other.

Quotient The result of a division question; the quotient tells how many times one number is contained in the other.

Radius The distance from the centre of a circle to the outside of the circle.

Ratio The relationship between two or more quantities. Eg. the ratio of men to women in the armed forces is 10 to 3 (10:3)

Reciprocal A number, when multiplied by its reciprocal, equals 1. To find the reciprocal of a common fraction, invert it. $\frac{3}{5} \times \frac{5}{3} = 1$

Reduce Write a common fraction in lowest terms. Divide both terms by same factor.

Remainder The amount left when a divisor does not divide evenly into the dividend. The remainder must be less than the divisor.

Sign In mathematics, a symbol that tells what operation is to be performed or what the relationship is between the numbers.

- + plus, means to add
- minus, means to subtract
- × multiplied by, "times"
- ÷ divided by, division
- = equal, the same quantity as
- ≠ not equal
- ≈ approximately equal
- < less than
- > greater than
- ≤ less than or equal to
- ≥ greater than or equal to

Simplify See *reduce*.

Subtrahend The amount that is taken away in a subtraction question.

Sum The result of an addition question, the answer to an addition question.

Symbol A written or printed mark, letter, abbreviation etc. that stands for something else.

Term a) A definite period of time, such as a school term or the term of a loan.

b) Conditions of a contract; the terms of the agreement. c) In mathematics, the quantities in a fraction and in a ratio are called the *terms* of the fraction or the *terms* of the ratio. In an algebra equation, the quantities connected by a + or - sign are also called terms.

Total The amount altogether.

Transaction One piece of business. A transaction often involves money. When you pay a bill, take money from the bank or write a cheque, you have made a transaction.

Unit Any fixed quantity, amount, distance or measure that is used as a standard. In mathematics, always identify the unit with which you are working. Eg. 3 km, 4 cups, 12 people, \$76, 70 books, 545 g

Unit price The price for a set amount. Eg. price per litre, price per gram.

Unlike fractions Fractions which have different denominators.

Vertical in an up and down position; we are vertical when we are standing up. On a page, a vertical line is shown from the top to the bottom of the page.